



Original Notice

© 2019 Robotiq Inc.

Robotiq EPick Vacuum Gripper
for e-Series Universal Robots



Instruction Manual

LEAN 
ROBOTICS

robotiq.com | leanrobotics.org



AIR PICK

Original Notice

© 2019 Robotiq Inc.

Robotiq AirPick Vacuum Gripper
for Omron-TM Series Robots



Instruction Manual

LEAN 
ROBOTICS

robotiq.com | leanrobotics.org



AIR PICK

Original Notice

© 2019 Robotiq Inc.

Robotiq AirPick Vacuum Gripper
for TM Robots



Instruction Manual

LEAN 
ROBOTICS

robotiq.com | leanrobotics.org



Original Notice

© 2019 Robotiq Inc.

Robotiq EPick Vacuum Gripper
for TM Robots



Instruction Manual

LEAN 
ROBOTICS

robotiq.com | leanrobotics.org



E PICK

Original Notice

© 2019 Robotiq Inc.

Robotiq EPick Vacuum Gripper
for Omron-TM Series Robots



Instruction Manual

LEAN 
ROBOTICS

robotiq.com | leanrobotics.org

Revisions	10
1. General Presentation	12
1.1. Gripper nomenclature	12
1.1.1. EPick Gripper	12
1.1.2. Suction Cup System	13
1.2. Object picking	14
1.2.1. Main unit suction cup	14
1.2.2. Auxiliary system with multiple suction cups	14
1.3. Setup and control	14
2. Safety	16
2.1. Warning	17
2.1.1. Risk assessment and final application:	17
2.2. Intended Use	18
3. Installation	20
3.1. Scope of Delivery	20
3.1.1. Robotiq EPick Vacuum Gripper Kit	20
3.2. Required Tools and Equipment	22
3.2.1. EPick Gripper Add-On	22
3.2.2. Suction cup system	22
3.3. Environmental and Operating Conditions	22
3.4. Mechanical Installation	23
3.4.1. Installing the Vacuum Gripper onto the robot	23
Single Gripper	23
Multiple Vacuum Grippers	25
3.4.2. Air tubing	26
Connection of the suction cup systems	26
3.4.3. Suction cup system	27
Manifold and mounting bracket	27
Suction cups and air nodes	29
3.5. Electrical Setup	29
3.5.1. Pinout interface	30
3.5.2. Coupling to controller	31
3.5.3. Coupling to wrist	32



Single Gripper	32
Multiple Grippers	33
3.6. Installation for Universal Robots	33
3.7. URCap Package	34
3.7.1. Installing URCap package on e-Series	35
Single Gripper	35
Multiple Grippers	37
3.7.2. Uninstalling URCap Package	39
3.7.3. License Agreement	40
<hr/>	
4. Software	43
4.1. Overview	43
4.1.1. Control using registers	43
4.1.2. Control over Universal Robots package	44
4.2. Vacuum Gripper register mapping	45
4.3. Robot output registers & functionalities	45
4.4. Robot input registers & status	49
4.5. Gripper behavior	52
4.5.1. Control modes	52
Automatic mode	52
Advanced mode	53
Very porous material detection	55
Object lost/ drop behavior	55
Object secured behavior	55
Object not detected behavior	56
Object release delay	56
Emergency stop behavior	56
4.6. Control logic	56
4.7. Modbus RTU communication	56
4.7.1. Connection setup	57
4.8. Control over Universal Robots with URCap	57
4.8.1. Vacuum Gripper Scan	59
4.8.2. Vacuum Gripper Toolbar	60
Overview	60
Features	60



4.8.3. Vacuum Gripper node	61
Command window	61
Grip Command	62
Release Command	63
Features	64
Advanced Vacuum Gripper Functions	64
5. User Interface	66
6. Specifications	67
6.1. Technical dimensions	67
6.1.1. Gripper	67
6.1.2. Suction Cup System	69
Manifold	69
Bracket for 2 suction cups	69
Bracket for 4 suction cups	70
6.1.3. Air nodes	72
6.1.4. Couplings	73
Blank coupling	73
Coupling for ISO 9409-1-50-4-M6	74
Coupling for ISO 9409-1-31.5-4-M5	75
Coupling for ISO 9409-1-40-4-M6	76
Coupling for PCD 56 with 8 x M4	77
Coupling for PCD 56 with 6 x M4	78
Coupling for PCD 60 with 4 x M5	79
Coupling for PCD 63 with 6 x M6	80
6.2. Mechanical specifications	81
6.2.1. Payload and force	83
Example 1: Non-porous material	85
Case #2	86
Example 2: Porous material	86
Case #1	88
6.2.2. Center of mass and tool center point	89
6.2.3. Moment Limitation	90
6.3. Electrical specifications	90



7. Maintenance	91
7.1. Vacuum Gripper cleaning	92
7.2. Periodic inspection	93
Suction cups and air nodes	94
8. Spare Parts, Kits and Accessories	95
9. Troubleshooting	98
9.1. Communication	98
9.2. Vacuum Gripper verification	100
10. Warranty	101
11. Harmonized Standards, Declarations and Certificates	103
11.1. Original EC declaration of incorporation	103
11.2. Applied standards	104
12. Contact	105



Revisions

Robotiq may modify this product without notice, when necessary, due to product improvements, modifications or changes in specifications. If such modification is made, the manual will also be revised, see revision information. See the latest version of this manual online at: support.robotiq.com.

2019-08-15

- Add of Multiple Grippers sections

2019-06-14

Initial release



Copyright

© 2016-2019 Robotiq Inc. All rights reserved.

This manual and the product it describes are protected by the Copyright Act of Canada, by laws of other countries, and by international treaties, and therefore may not be reproduced in whole or in part, whether for sale or not, without prior written consent from Robotiq. Under copyright law, copying includes translation into another language or format.

Information provided by Robotiq in this document is believed to be accurate and reliable. However, no responsibility is assumed by Robotiq for its use. There may be some differences between the manual and the product if the product has been modified after the edition date.

The information contained in this document is subject to change without notice.



1. General Presentation

The terms "Gripper", "EPick Gripper", "EPick Vacuum Gripper" and "EPick" used in the following manual all refer to the Robotiq EPick Vacuum Gripper. The Robotiq EPick Vacuum Gripper is a robotic peripheral designed for industrial applications. The vacuum is generated with an electric vacuum pump. Its design makes it a unique robotic end-of-arm tool to quickly pick, place and handle a large range of parts of varying sizes and shapes.

Info

The following section presents the key features of the Gripper and must not be considered as appropriate to the operation of the Gripper. Each feature is detailed in the appropriate section.

Info

The following manual uses the metric system. Unless specified, **all dimensions are in millimeters.**

1.1. Gripper nomenclature

1.1.1. EPick Gripper

The EPick Gripper is a vacuum Gripper that generates a vacuum with an electric vacuum pump. It is equipped with one or multiple suction cups. Each suction cup can be adapted to your application and grasping needs. The EPick Gripper is compatible with the Robotiq standard coupling interface.



Fig. 1-1: Robotiq EPick Gripper



Info

Please refer to the **Scope of Delivery** section subsection and the **Spare Parts, Kits and Accessories** section for details on standard and optional parts.

112. Suction Cup System

A Robotiq Suction Cup System can be installed directly under the Vacuum Gripper. Each Robotiq Suction Cup System includes a bracket, a manifold, air nodes, port plugs, bumpers, tubing and additional suction cups.



Fig. 1-2: Suction cup system

Info

Please refer to the **Installation** section for more information on how to integrate the Suction Cup System to EPick.

Info

Please refer to the **Scope of Delivery** section subsection and the **Spare Parts, Kits and Accessories** section for details on standard and optional parts.

Tip

The owner can use a custom bracket or a mounting plate. The bracket or mounting plate can be installed directly under the manifold.



12. Object picking

The EPick allows:

1. Main unit suction cup
2. Auxiliary system with multiple suction cups

Warning

Object picking causes the compression of the suction cup(s) , which can result in pinching points between the gripper and the load. Avoid presence of body parts in this zone during operation.

Warning

Before picking any new object or material in autonomous mode, always check that the resulting vacuum level is sufficient to ensure safe gripping, in order to prevent dropping or ejection of the load.

12.1 Main unit suction cup

In order to use only one suction cup, the single cup can be mounted right in the port of the vacuum generator.

12.2. Auxiliary system with multiple suction cups

A standard Suction Cup System can be attached to the EPick Vacuum Gripper. The bracket normally holds two or four suction cups (corresponding to the four ports of the manifold).

Any unused manifold port should be blocked with a mating plug to avoid air leakage.

Other custom mounting options can also be used to benefit from a multiple suction cups solution

Caution

Custom brackets and plates must meet the required technical specifications (refer to the **Technical dimensions** section subsection).

13. Setup and control

The Vacuum Gripper is powered and controlled directly via a single device cable that carries 24 V DC power and Modbus RTU communication over RS-485.

Info

Please refer to the **Electrical Setup** section subsection for wiring information, and to the **Software** section for the control of the Vacuum Gripper.

In order to be used, the EPick Gripper has to be connected to a Gripper coupling which provides both the mechanical and electrical connectivity to the Gripper.



Info

Please refer to the **Mechanical Installation** section for more information on mounting the Vacuum Gripper onto the coupling. Refer to the **Technical dimensions** section for the technical drawing, and refer to the **Spare Parts, Kits and Accessories** section for a list of the available couplings.

The EPick Gripper boasts an embedded object detection feature which uses indirect sensing measurements. The system thus indicates if the workpiece has been dropped or if the Gripper failed to grasp the workpiece.

Info

For more information regarding the object detection feature, please refer to the **Software** section.



2. Safety

Warning

The operator must have read and understood all of the instructions in the following manual before operating the Robotiq Vacuum Gripper.

Caution

The term “operator” refers to anyone responsible for any of the following operations on the Robotiq Vacuum Gripper:

- Installation
- Control
- Maintenance
- Inspection
- Calibration
- Programming
- Decommissioning

This manual covers the various components of the Robotiq Vacuum Gripper and the general operations regarding the whole life-cycle of the product, from installation to operation and decommissioning.

The drawings and photos in this manual are representative examples. However, discrepancies may be observed between the visual supports and the actual product.



2.1 Warning

Caution

Any use of the Gripper in non-compliance with these warnings is deemed inappropriate and may cause injury or damage.

Warning

- Always use the suction cup system and its components (air nodes, port plug, etc.) with the Robotiq Vacuum Gripper only.
- Never operate the Vacuum Gripper with leaking or worn parts.
- The Vacuum Gripper needs to be properly secured before operating the robot.
- Do not install or operate a Gripper that is damaged or lacking parts.
- Never supply the Gripper with an alternating current source.
- Make sure all cord sets are always secured at both ends—Gripper and robot.
- Always meet the recommended keying for electrical connections.
- Make sure no individuals or assets are in the vicinity of the robot and/or Gripper prior to initializing the robot.
- Always meet the Gripper's payload specifications.
- Set your vacuum level based on your application.
- Keep body parts and clothing away from the Gripper while the device is powered on.
- Do not use the Gripper on people or animals.
- Never stand under suspended loads held by the Vacuum Gripper.

2.1.1 Risk assessment and final application:

The Robotiq Vacuum Gripper is meant to be used on cobots and industrial robots.

The robot, the Gripper and any other equipment used in the final application must go through a comprehensive risk assessment process before they can be used. Special care must be taken during this step if custom mounting options are used for the suction cups.

Caution

It is the robot integrator's responsibility to ensure that all local safety measures and regulations are met.

The following non-exhaustive list presents risks that must be assessed during the integration process:

- Risk of contact between body parts and suction cups during gripping;
- Risk of load ejection resulting from loss of vacuum;
- Risk of load dropping resulting from loss of vacuum;



- Risk of pinching between the Vacuum Gripper and the part(s) or the environment;
- Risk of damage or breaking if using a custom suction cup bracket that does not meet the technical requirements.

Depending on the application, there may be hazards that require additional protection and/or safety measures. For instance, the workpiece handled by the Gripper could be inherently dangerous to the operator.

Warning

Depending on the supply sources, when an emergency stop (e-Stop) button is pressed, the following consequences may occur. The robot owner has the responsibility to do a risk assessment and choose the appropriate option.

Supply sources	e-Stop consequences
Robot tool supply (tool connector)	Power failure to the Vacuum Gripper. The vacuum level will drop to ambient pressure and the object will be lost.
Robot controller supply (Any 24V pin)	Vacuum Gripper powered ON. <ul style="list-style-type: none"> • If an object is detected: the vacuum level will continue to be regulated and the object will not be lost. • If no object is detected: the Vacuum Gripper will go into a standby state 2 seconds after the e-Stop button is pressed.

Warning

Loss of vacuum can occur due to power failure.

2.2. Intended Use

The Gripper unit is designed for gripping and temporarily securing or holding objects.

Caution

The Gripper is NOT intended for applying force against objects or surfaces.

The product is intended for installation on a robot or other automated machinery and equipment.

Info

Always comply with local, state, province and/or federal laws, regulation and directives regarding automation safety and general machine safety.



The unit should be used exclusively within the range of its technical data. Any other use of the product is deemed improper and unintended. Robotiq will not be liable for any damages resulting from any improper or unintended use.



3. Installation

The following subsections will guide you through the installation and general setup of your Robotiq Vacuum Gripper.

Warning

Before installing:

- Read and understand the safety instructions related to the Vacuum Gripper.
- Verify your package according to the scope of delivery and your order.
- Make sure to have the required parts, equipment and tools listed in Scope of delivery.

Warning

When installing:

- Meet the recommended environmental conditions.
- Do not operate the Vacuum Gripper, or even turn on the power supply, before the device is firmly anchored and the machine area is cleared. Make sure that the air supply is secured.

3.1. Scope of Delivery

3.1.1. Robotiq EPick Vacuum Gripper Kit

Standard upon delivery:

- **Standard Kit**
 - One (1) electrical vacuum generator
 - Two (2) standard suction cups (two different sizes)
 - One (1) End effector coupling kit
 - One (1) USB stick
 - Required hardware
- **2 Suction Cups Kit**
 - One (1) Vacuum generator
 - One (1) suction cup system for 2 suction cups (1 manifold, 1 bracket, tubing, 2 air nodes, 4 suction cups)
 - Four (4) standard suction cups (two different sizes)



- Four (4) port plugs (two already mounted on the suction cup system)
- One (1) End effector coupling kit
- Required hardware

- **4 Suction Cups Kit**

- One (1) Vacuum generator
- One (1) suction cup system for 4 suction cups (1 manifold, 1 bracket, tubing, 4 air nodes, 8 suction cups)
- Eight (8) standard suction cups (two different sizes)
- Four (4) port plugs
- One (1) End effector coupling kit
- Required hardware

Info

Please refer to the **Spare Parts, Kits and Accessories** section for a list of available couplings.

Caution

The following are not included in the standard delivery:

- Options such as custom suction cup brackets/plates or couplings for mounting on various industrial robots.
- Hardware required for accessories or fixtures, unless specified.



Info

When purchased as a kit, the EPick Vacuum Gripper will come in a package with the appropriate coupling, suction cups and cabling.

Please refer to the **Spare Parts, Kits and Accessories** section for additional components.

3.2. Required Tools and Equipment

3.2.1 EPick Gripper Add-On

The following tools are required to install the Vacuum Gripper:

- Hex key to mount the coupling onto the robot, according to your coupling
- 4 mm hex key to mount the Vacuum Gripper onto its coupling .
- 3 mm hex key to mount the connector protector

3.2.2. Suction cup system

The following tool is required to install the Suction cup system on the Vacuum Gripper:

- 4 mm hex key to assemble together the suction cup system and the vacuum generator.

3.3. Environmental and Operating Conditions

CONDITION	VALUE
Minimum storage/transit temperature	-30°C [-22°F]
Maximum storage/transit temperature	60°C [140°F]
Minimum operating temperature	5°C [41°F]
Maximum operating temperature	40°C [104°F]
Humidity (non-condensing)	20-80% RH
IP Rating	IP 4X

Table 3-1: Environmental and operating conditions of the EPick Vacuum Gripper

Caution

Use of the Vacuum Gripper is not recommended in presence of chemicals in the environment.



Info

The input filter prevents any dust larger than 200 µm from getting inside the pump. Dry dust will prevent the accumulation on filters or inside the pump. The use of suction cups with integrated filter can be used to reduce dust accumulation.

The exhaust must not be blocked.

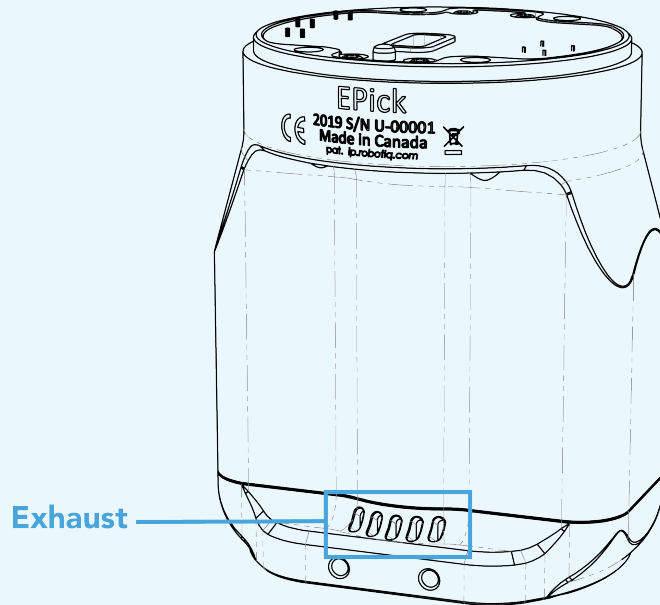

3.4. Mechanical Installation

3.4.1. Installing the Vacuum Gripper onto the robot

Single Gripper

For purposes of power and communication, a coupling must be used to attach the Vacuum Gripper to the robot.

Here are the steps to follow to mount the Gripper on the robot arm (exploded view in figure below). Please note that all screws should be secured using medium strength threadlockers.

1. Mount the coupling on the robot wrist using the provided M6 screws and tooth lock washers. Align properly with the dowel pin. The dowel pin is meant to have a tight fit on the robot side and a slip fit on the effector side of the assembly.
2. Fasten the Gripper to the coupling using the provided M5 screws and tooth lock washers.
3. Plug the coupling's cable into the robot's wrist connector.
4. Cover the connection using the protector and the provided M4 screws.



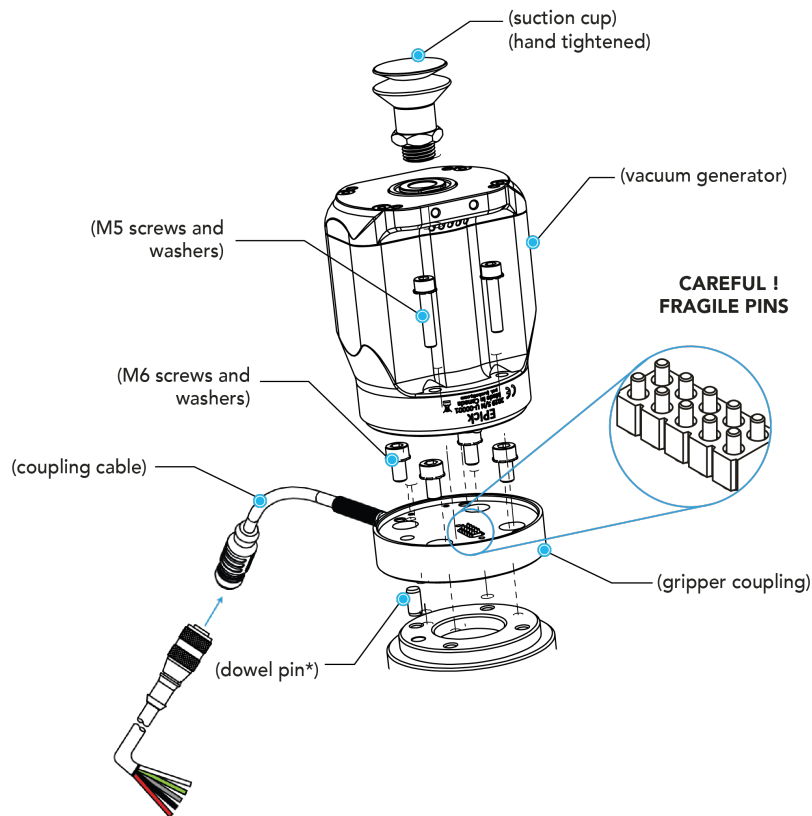
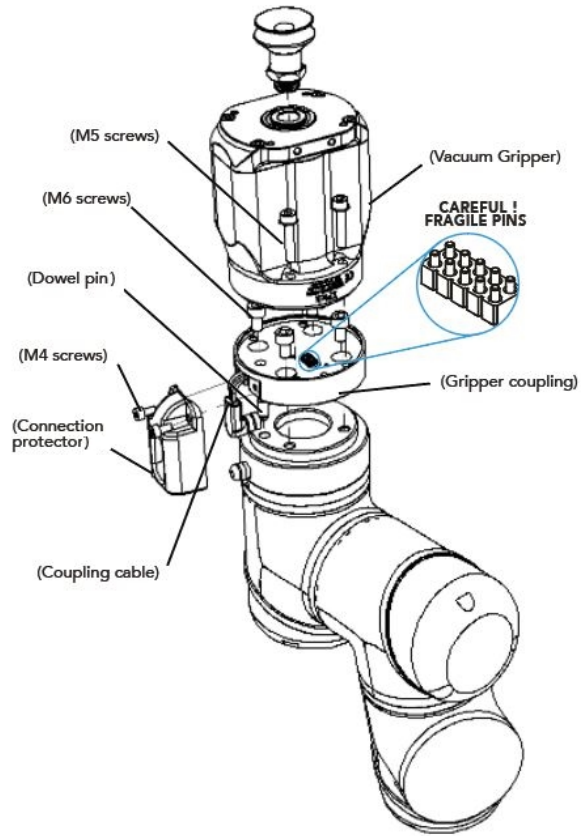

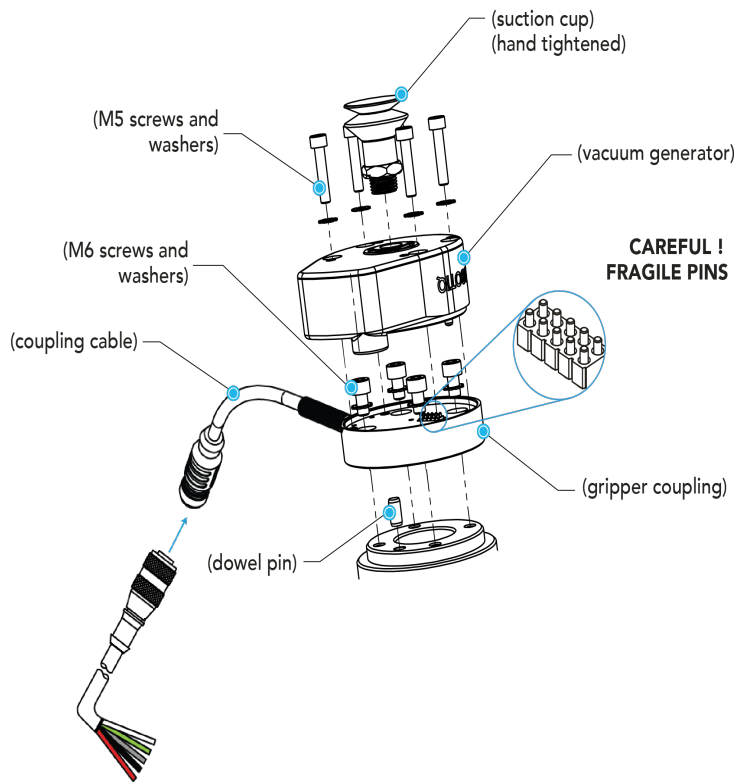

Fig. 3-1: Installing the Vacuum Gripper onto the robot wrist

Multiple Vacuum Grippers

When installing multiple Vacuum Grippers on one robot, every Vacuum Gripper must have its own coupling.

1. Fasten the M8 splitter (ACC-SPLIT-M8-2:1) to the dual vacuum gripper adapter plate (AGC-APL-159-002).

Caution

Make sure the splitter is fastened on the side of the adapter plate that receives the dowel pin.

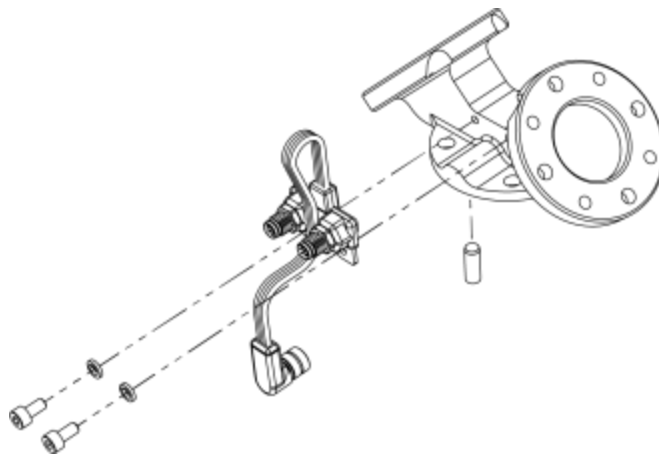

Fig. 3-2: Installation of the Wrist Connector Splitter for Mounting a Dual Gripper on e-Series



2. Mount the adapter plate on the robot tool flange.
3. Mount the gripper couplings on the adapter plate using the provided M6 screws.
4. Mount the Vacuum Grippers onto their coupling using the provided M5 screws.

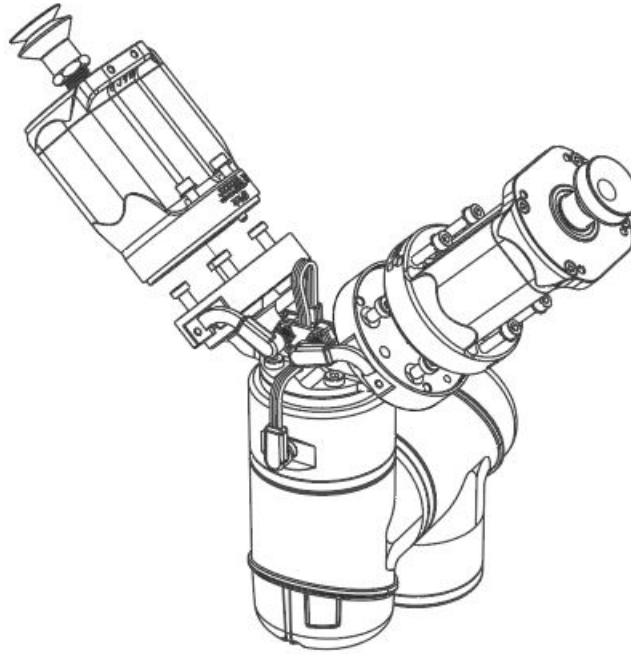

Fig. 3-3: Exploded view of a dual Vacuum Gripper setup

3.4.2. Air tubing

Connection of the suction cup systems

To ensure vacuum distribution to the suction cups, connect the appropriate manifold ports with the pertaining air nodes using the provided plastic tubing.

Info

To facilitate the assembly of the Robotiq Wrist Camera on the suction cup system, make sure to place the tubing as shown in the figure to be assured that there will be no interference with the camera's field of view while preventing excessive tube bending.



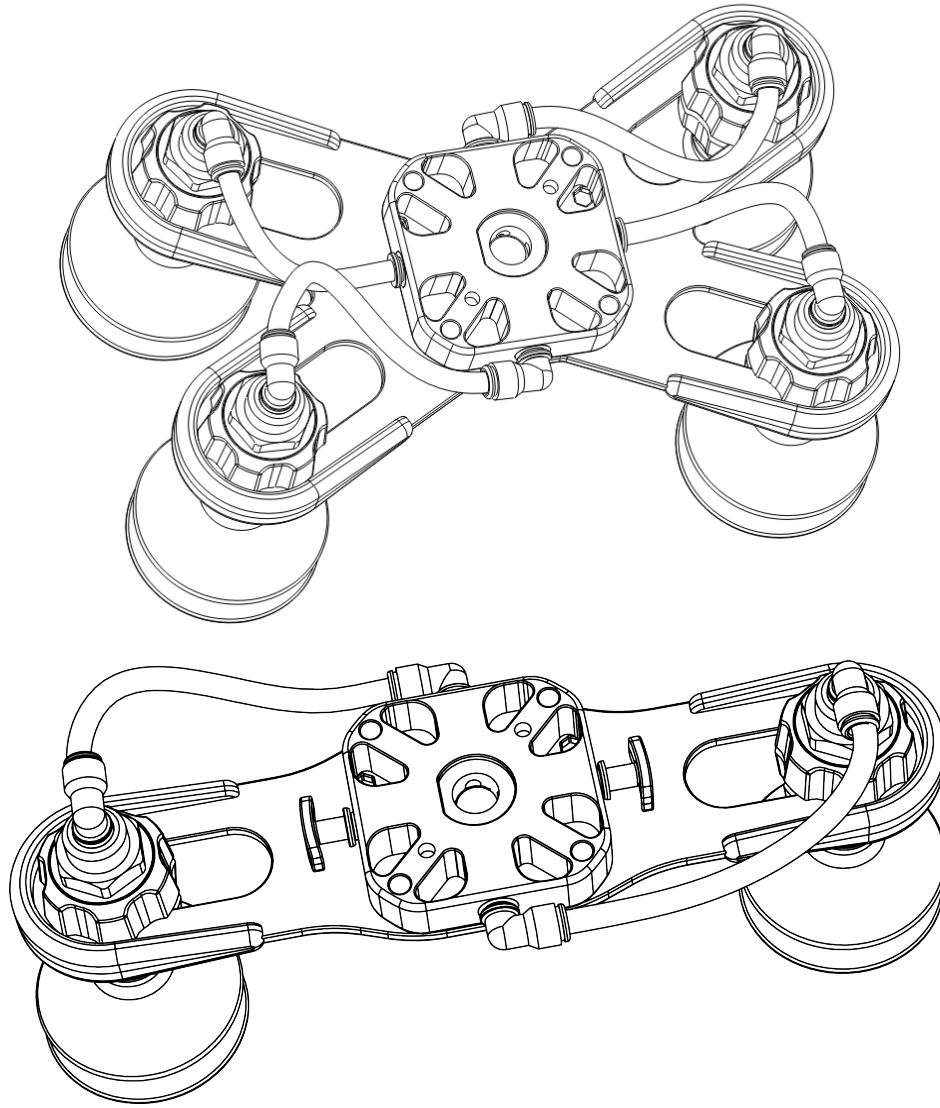

Fig. 3-4: Air tubes alignment

3.4.3. Suction cup system

Manifold and mounting bracket

In order to use the two (2) or the four (4) Suction Cups System, assemble the vacuum generator to the suction cup system, as shown in the figure below, using four (4) M5 socket head cap screws and four (4) M5 toothlock washers.



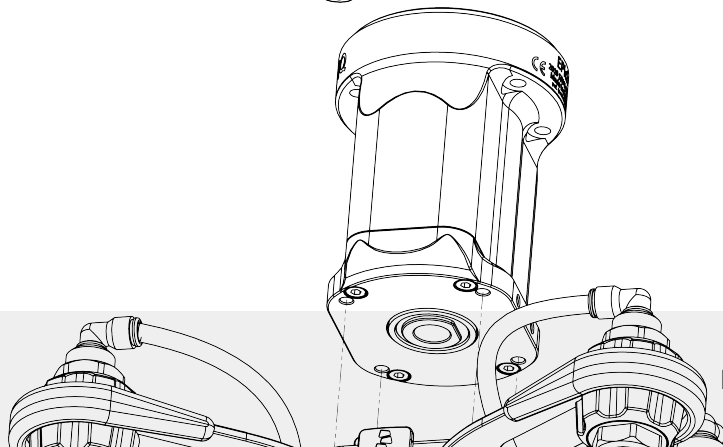
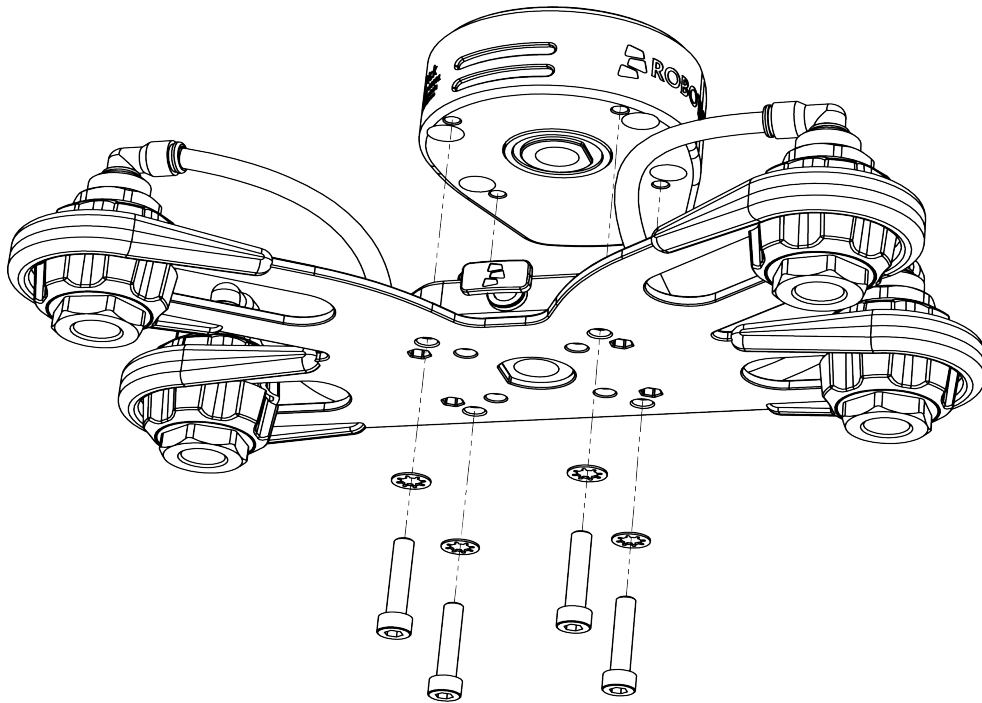
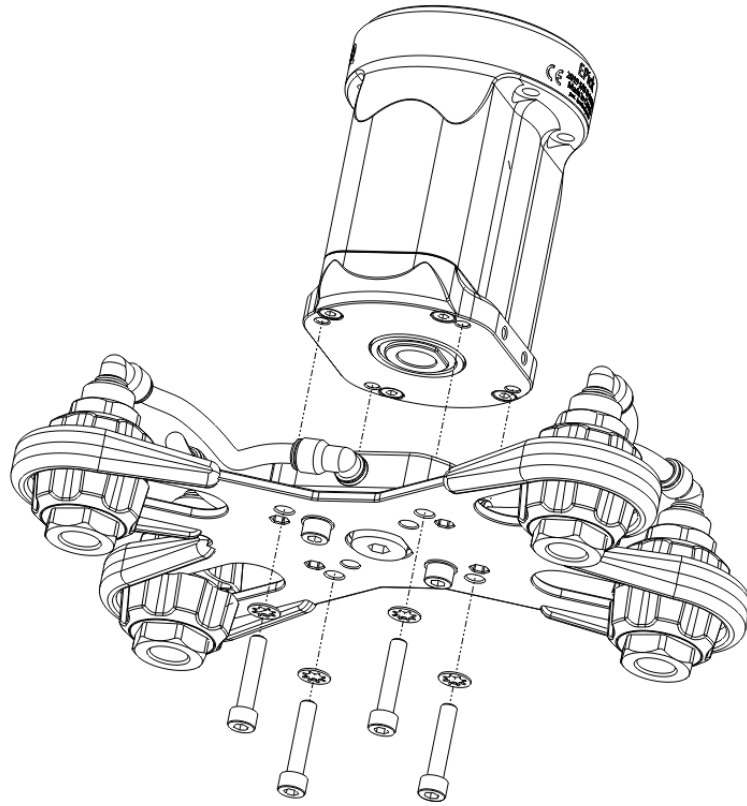

Warning

Any unused manifold port should be covered with a provided port plug to avoid air leakage. For more details, please refer to the **Manifold** section

Suction cups and air nodes

Whether you are using a standard or custom option, air nodes should be used to connect the suction cups and the air tubing, and to prevent air leakage as much as possible. Air nodes are easy to assemble, as shown in the figures below.

1. Screw by hand each provided vacuum cup to an air bolt.

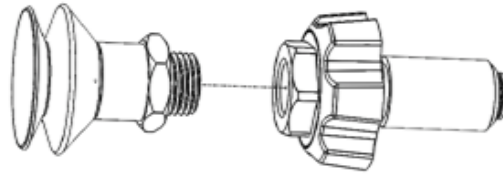

Fig. 3-6: Screwing a vacuum cup and an air bolt

2. Pass each air bolt through the mounting bracket, adjust the position of the node along the bracket side, align with mating air nuts and tighten node by hand.

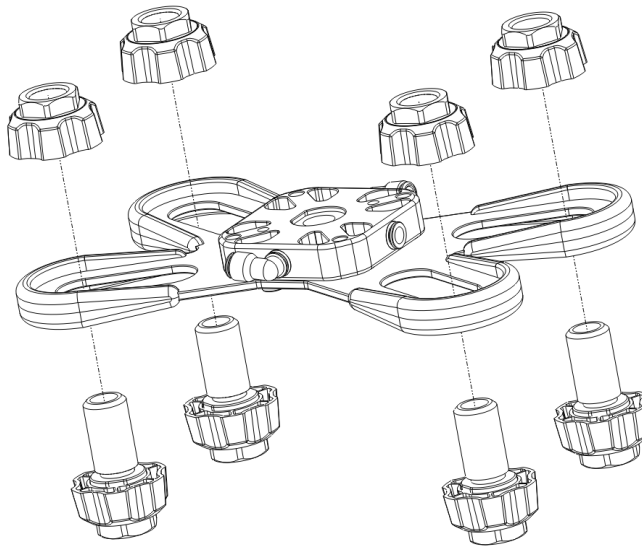

Fig. 3-7: Mounting air nodes (vacuum cups, air bolts, air nuts) on the bracket

3.5. Electrical Setup

Power and communication are established with the Gripper via a single device cable. The device cable provides a 24 V power supply and enables serial RS-485 communication to the robot controller.

Info

RS-485 signals (485+, 485- and 485 GND) are isolated from the main 24 V power supply. GND can be connected to any other ground reference as long as the voltage potential between the grounds does not exceed 250 V. Grounding reference is at the user's discretion.

3.5.1 Pinout interface

The Gripper interfaces with its coupling via a 10-spring pin connector located on its outer surface.

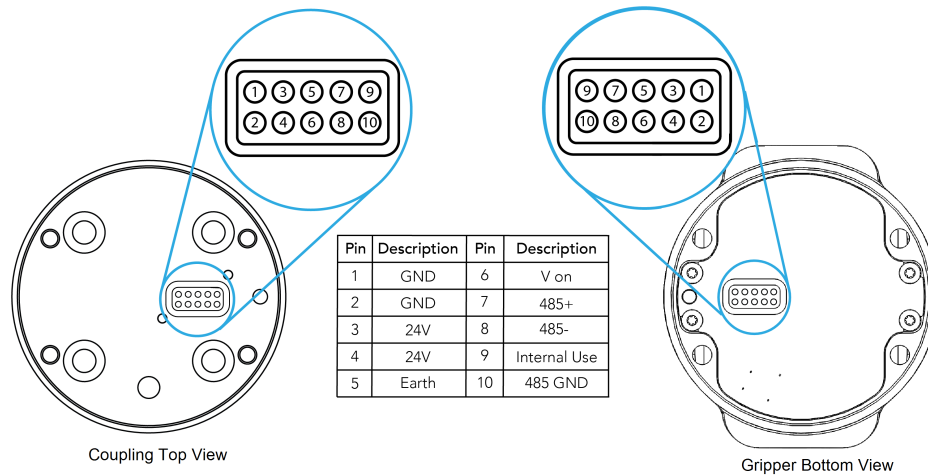

Fig. 3-8: Pinout of the EPick cable-to-wrist coupling.



Info

The coupling used in the figure above is used for reference only and corresponds to bolt pattern ISO 9409-1-50-4-M6.

3.5.2. Coupling to controller

Tip

In order to connect the Vacuum Gripper to the controller, please refer to the CB-Series instruction manual of this Gripper.



3.5.3. Coupling to wrist

Single Gripper

The figure below represents the wiring schematic of the Vacuum Gripper with a coupling connecting directly to the robot wrist.

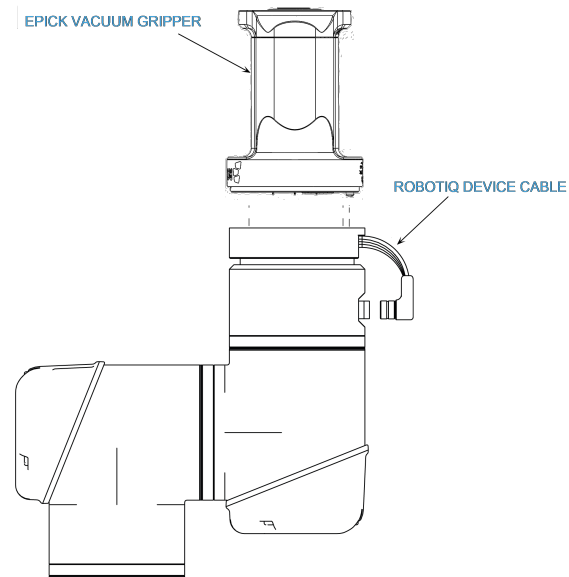
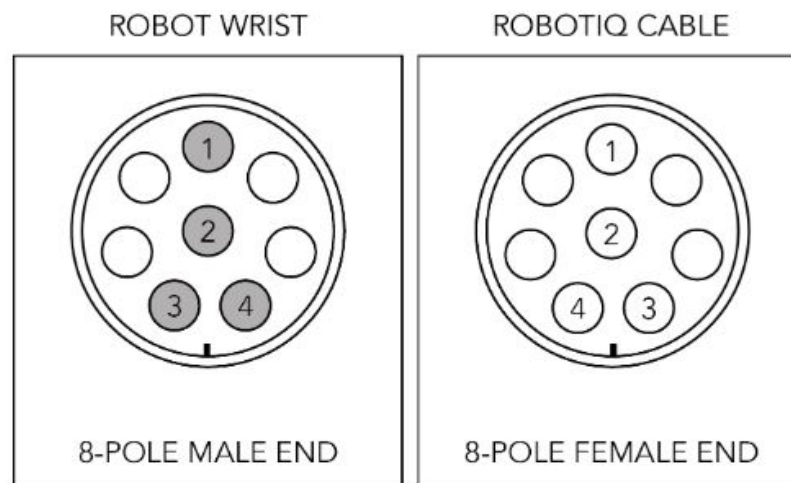

Fig. 3-9: Robotiq EPick Gripper with device cable wiring scheme



PIN	SIGNAL
1	24V
2	GND
3	RS485 +
4	RS485 -

Fig. 3-10: Pinout of the Vacuum Gripper cable-to-wrist coupling

Info

Power supply, communication signals, grounding, electrical resistance and fusing are managed by the robot itself.

Multiple Grippers

It is possible to connect more than one vacuum gripper to the wrist of the Universal Robot.

Warning

In order to connect two or more Vacuum Grippers at the same time on an e-Series robot, you must have a coupling (GRP-ES-CPL-062) for the transmission of power and communication signals, a dual gripper adapter plate (AGC-APL-159-002) to mechanically mount the Vacuum Grippers on the robot arm, and an M8 splitter (ACC-SPLIT-M8-2.1). Please refer to the Spare Parts, Kits and Accessories section for more details.

Refer to the **Installation** section for a visual representation of the two components to assemble in order to mount two grippers on the robot:

- M8 splitter (ACC-SPLIT-M8-2:1)
- Dual gripper adapter plate for Universal Robots (AGC-APL-159-002)

Caution

The M8 Splitter and the adapter plate come unassembled. The splitter must be fastened on the side of the adapter plate that receives the dowel pin.

3.6. Installation for Universal Robots

The table below shows which Robotiq software to use with your Universal Robots' controller. Please refer to the URCap Package section for the installation of the UR software package for the Vacuum Gripper.

Robotiq Software	CB3.1 Controller	e-Series Controller
Robotiq Grippers URCap Package 1.5.1 and earlier versions	Incompatible	Incompatible
Robotiq Grippers URCap Package 1.6.0 and later versions	Compatible	Compatible

Table 3-2: Compatibility between Robotiq software and the robot controller

Caution

The robot's PolyScope version must be 3.7 and later in order to install the URCap package.

Caution

Prior to use over Universal Robots, adjust the payload and the center of gravity in the Installation tab. Refer to the Mechanical specifications subsections.

Caution

Please refer to the Installing URCap Package section to configure the Gripper properly before operating and programming the device.

3.7. URCap Package

Robotiq provides the user with a Universal Robots URCap package that provides a graphical user interface and enables direct serial communication to your UR controller.

Info

Browse to the [Vacuum Gripper support page](#) to download the URCap package.

Make sure the Gripper is properly mounted onto the robot arm. Refer to the **Mechanical Installation** section for detailed information.

Before proceeding with the installation of the URCap package, make sure your Universal Robots controller is compatible with the package (refer to the **Installation for Universal Robots** section).

Caution

The robot's PolyScope version must be 3.7 or later in order to install the URCap package.

The Gripper's URCap package contains:

- The URCap for the Gripper
- The Vacuum Gripper toolbar
- The Vacuum node(s)

For details on controlling the Gripper, please refer to the **Software** section.

Info

Please refer to the **Control over Universal Robots with URCap** section for detailed information on how to program using the URCap package.



3.7.1 Installing URCap package on e-Series

Single Gripper

Make sure the Gripper is properly mounted to the robot arm. Refer to the **Mechanical Installation** section for detailed information.

Before proceeding with the installation of the URCap package, make sure your Universal Robots controller is compatible with the package (refer to the Installation for Universal Robots subsection).

Info

Tap the **triple bar icon** and select the **About** button to view the UR software version.

Follow this procedure to install the Vacuum Gripper URCap package:

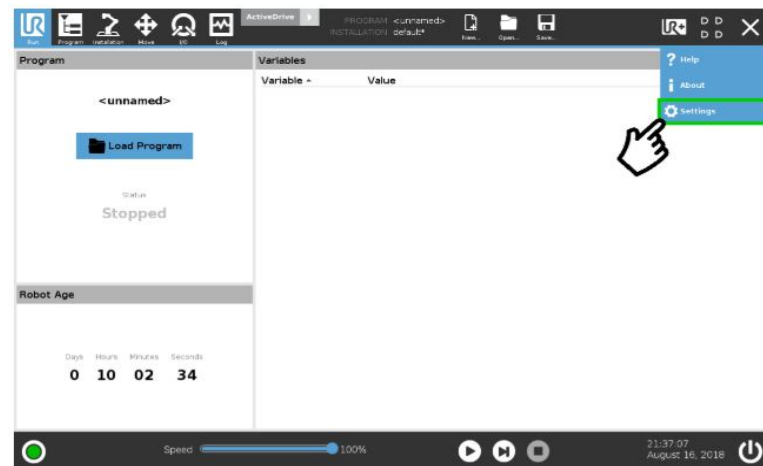
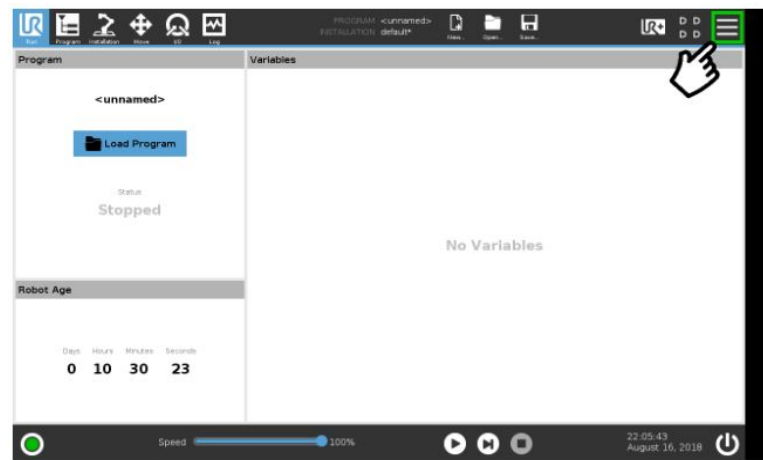

- Make sure that your PolyScope version is up-to-date and that your Universal Robots controller is compatible with the Gripper's URCap package.
- Go to support.robotiq.com, and select the Universal Robots brand.
- Select EPick .
- Click on Software → Gripper Software
- Download the corresponding URCap and extract it on the root of a blank USB stick.
- Insert the USB stick in the UR teach pendant or controller.
- On the teach pendant, tap the **triple bar icon** in the upper right corner of the screen.
- Tap **Settings**.



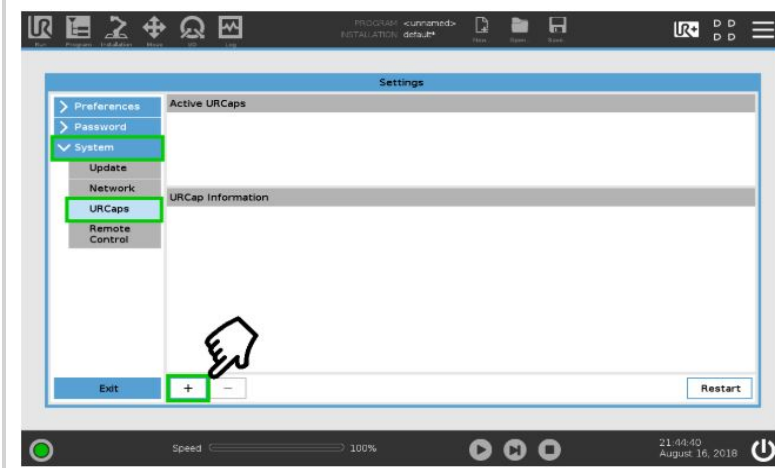

- Tap the **System** button in the navigation pane on the left.
- Select **URCaps** in the dropdown list.
- Press the **plus (+)** button to look for the .urcap file in the available drives.

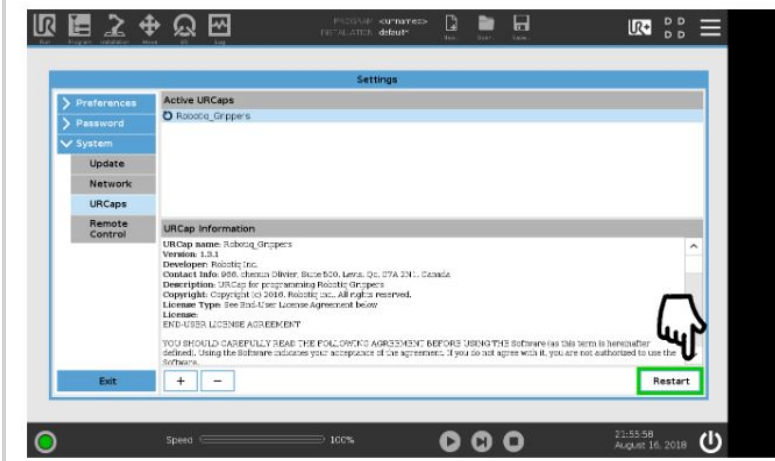

- Once the file is selected, it will display in the **Active URCaps box**, next to a rounded arrow.
- Tap the **Restart** button to activate the URcap.



Multiple Grippers

It is possible to connect and control up to four Vacuum grippers on the same UR robot.

When installing multiple grippers on one UR robot, their gripper ID must be set properly.

Caution

Connect only one gripper at a time using the M8 splitter (refer to the Installing the Gripper onto the robot section and the Electrical Setup section for detailed instructions); i. e. disconnect the gripper once it has been set up and identified by the software.

To do so, perform the following steps for each Vacuum Gripper:

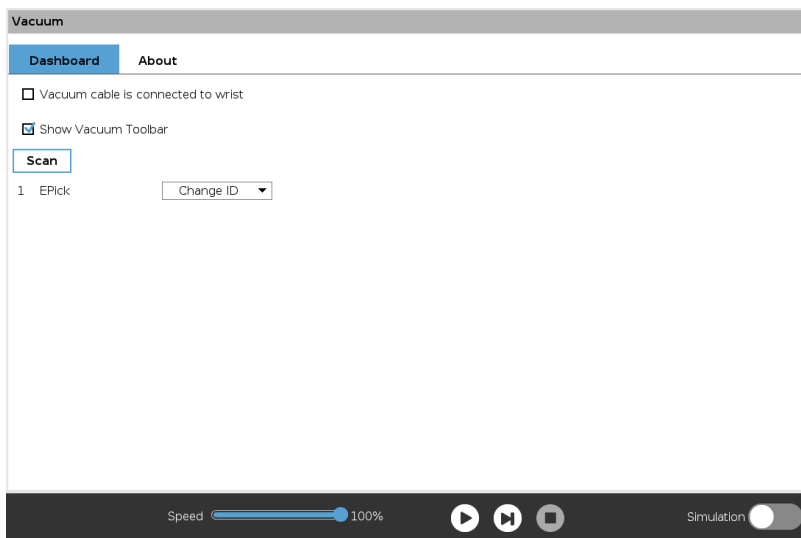

- On the teach pendant, tap the **Installation** button in the ribbon at the top of the screen.
- Select **URCaps** in the navigation pane on the left.
- Tap on **Vacuum Gripper**.
- Select the **Dashboard** menu.
- Tap the **Scan** button to detect Grippers.

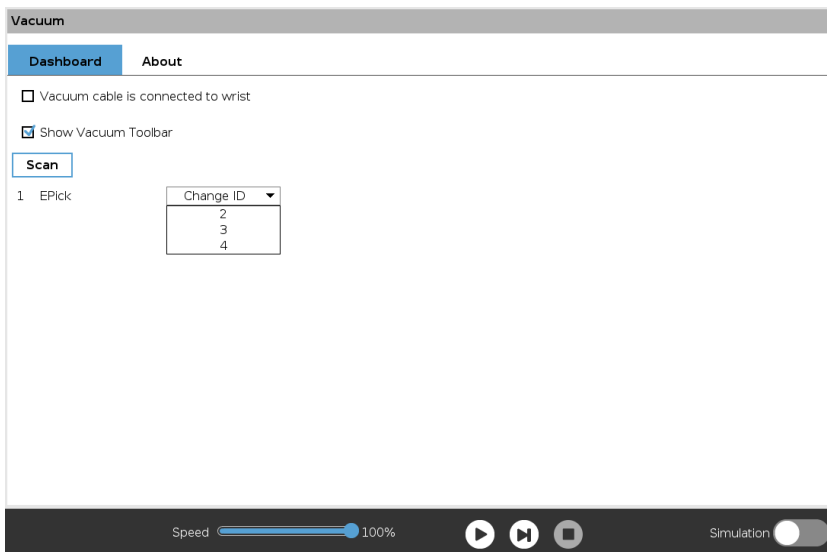

- Change the Vacuum Gripper ID to the desired one.
- Make sure it is different from the other Gripper IDs.
- Vacuum Gripper ID is saved to the Vacuum Gripper's internal memory. ID will be kept at all time.
- Click on Activate to activate the Vacuum Gripper.
- Perform the same routine for all grippers, if applicable, connecting only one at a time.

Caution

Make sure all Vacuum Grippers have different IDs. With their factory settings, all grippers have Gripper ID set to 1. If you have more than one gripper connected with the same ID, communication issues will arise.



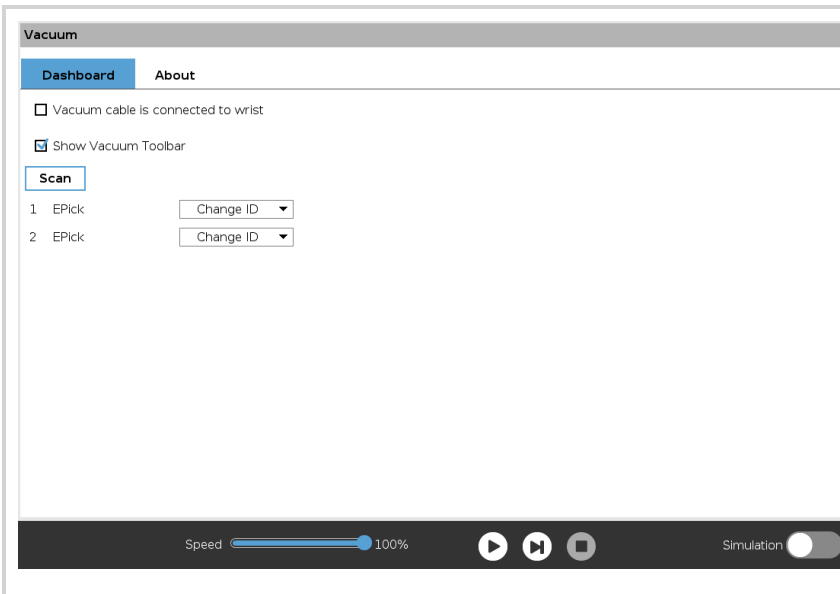

- Once all grippers IDs have been set, connect them all to the M8 splitter.
- Go back to the **Dashboard** tab and confirm that all grippers are recognized and can be controlled.



3.7.2. Uninstalling URCap Package

If you want to uninstall the Vacuum Gripper URCap, follow the procedure below:

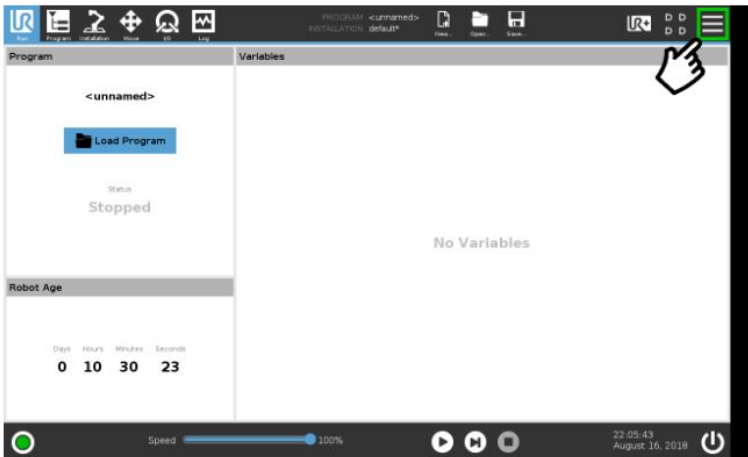

- On the teach pendant, tap the **triple bar icon** in the upper right corner of the screen.

- Tap **Settings**.

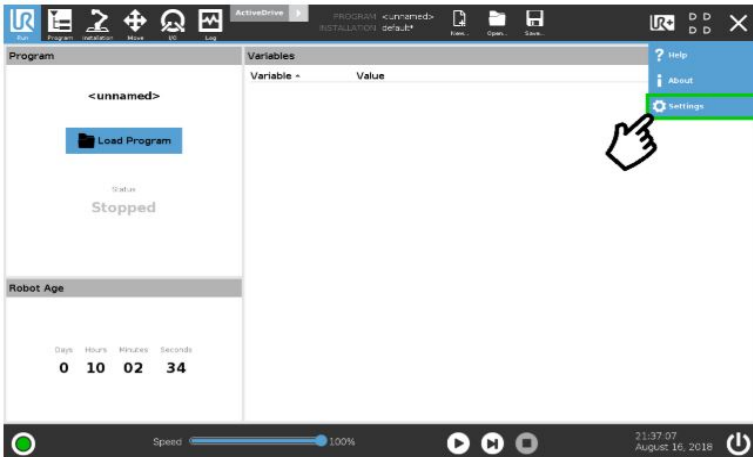

- Tap the **System** button in the navigation pane on the left.
- Select **URCaps** in the dropdown list.
- Press the **minus (-)** button to remove the URCap package.
- Tap the **Restart** button to deactivate the URCap.



3.7.3. License Agreement

END-USER LICENSE AGREEMENT

YOU SHOULD CAREFULLY READ THE FOLLOWING AGREEMENT BEFORE USING THE Software (as this term is hereinafter defined). Using the Software indicates your acceptance of the agreement. If you do not agree with it, you are not authorized to use the Software.

IMPORTANT-READ CAREFULLY: This End-User License Agreement (the “ Agreement”) is a legal agreement between you and the Licensor (as this term is hereinafter defined), the licensor of the Software. This Agreement covers the Software. The Software includes any “ on-line” or electronic documentation and all modifications and upgrades related thereto. By installing, or otherwise using the Software, you agree to be bound by the terms of this Agreement. If you do not agree to the terms of this Agreement, the Licensor cannot and does not license the Software to you. In such event, you must not use or install the Software.

1. Definition.

1. “ UR” means Universal Robots A/S, a corporation incorporated under the laws of Denmark, having its registered office at Energivej 25, DK-5260 Odense S, which specializes into the conception, advanced manufacturing and sale of robotic products (the “ UR’s Business”);
2. “ Software” means any of the Licensor’s softwares provided to its customers for the purposes mentioned in Sub-section 1.4 hereof including their modifications and upgrades and their related materials;
3. “ Licensor” means Robotiq inc., a corporation incorporated under the laws of Quebec, having its registered office at 500-966 chemin Olivier, Lévis, Québec, Canada, G7A 2N1, which specializes into the conception, advanced manufacturing and sale of robotic products (the “ Licensor’s Business”);
4. “ End-User” means a customer authorized pursuant to this Agreement to install or use the Software in order to make a specific product from the Licensor’s Products compatible and functional with a specific product of the UR’s Product ;
5. “ Licensor’s Products” means those products developed by the Licensor in the course of the Licensor’s Business;
6. “ UR’s Products” means those products developed by UR in the course of the UR’s Business;
7. “ Licensor’s Authorized Representatives” means and includes the Licensor and Licensor’s authorized vendors, resellers, distributors and licensors;
8. “ Purchase Agreement” means an agreement between the End-User and the Licensor pursuant to which the End-User purchased one or more of the Licensor’s Products.

2. License. Subject to the terms and conditions hereof, the Licensor grants to the End-User a personal, temporary, non-exclusive, non-assignable and non-transferable and revocable license to use the Software in accordance with the terms and conditions hereof.

3. Software and Documentation. The Licensor may provide, if applicable, all documentation containing the detailed specifications for operation and use of the Software, which Software shall be used in accordance with such documentation. This documentation, if applicable, will be provided, wholly or in part, within (i) this Agreement, (ii) the Licensor’s Web site <http://robotiq.com/> (iii) the Licensor’s Products and the Purchase Agreement therewith, or (iv) any other agreement, document, support, whatsoever decided by the Licensor.

The use of the Software requires the Licensor’s Products, UR’s Products , compatible systems and certain software (which may require some expenses), may require periodical updating and may be affected by such elements. Most equipment will be compatible with the Software. However, the Software may not function on certain types of equipment.

4. Modifications and Upgrades. The Licensor shall be under no obligation to provide any upgrade or modification to the Software. However, the End-User shall be entitled to receive free of charge all modifications and upgrades of the Software provided by the Licensor if, at such time, the End-User is not in default in respect of any of its obligation contained herein. Such modifications and upgrades of the Software shall be installed by the End-User itself by consulting the Licensor’s Website <http://robotiq.com/> where



a link to proceed to such installation will be made available thereof. A new version of the Software shall not be covered by this Section 4 but shall require that a new End-User Software License Agreement be entered into between the Licensor and the End-User.

5. Fees. The grant by Licensor to the End-User of the present license shall be free to the extent that the End-User agrees and complies to the term and conditions herein at all time.
6. Maintenance. During the term of this Agreement, the Licensor will maintain the Software in an operable condition and will make available any corrections and improvements as are generally incorporated in the Software by the Licensor without additional charge to the End-User. The Licensor may temporarily and without notice suspend or limit access to the Software if necessary or desirable in order to maintain, restore, modify or repair any part of the Software or for any reason related to business. During such works, the Software will not be available but the Licensor undertakes to deploy its best efforts to perform such works at appropriate times and to limit any inconvenience arising therefrom.
7. Title to Software. The licensed Software is composed of confidential data and trade secrets and is proprietary to and constitutes trade secret information and intellectual property of the Licensor. Title and ownership rights to the Software, including the intellectual property rights related thereto, shall remain with the Licensor. The End-User agrees to maintain the confidential nature of the Software and related materials provided for the End-User's own internal use under this Agreement. The license granted herein does not include the right to sublicense to others, and may not be assigned to others, in whole or in part, without the prior written consent of the Licensor. The End-User may not or allow others to modify or prepare derivative works, copy (except for normal backups for recovery purposes), reproduce, republish, reverse engineer, upload, post, transmit, or distribute, in any manner, the Software.
8. Restricted Use. The Software shall be used solely and exclusively by the End-User and its employees for the purpose mentioned in Sub-section 1.4 hereof. Any other use of the Software, including resell derivative modifications or extensions, is expressly prohibited.
9. Exclusion of Warranty on Software. The End-User expressly acknowledges and agrees that use of the Software is at the End-User sole risk. The Software is provided "AS IS" and without warranty of any kind. THE LICENSOR AND THE LICENSOR'S AUTHORIZED REPRESENTATIVES DO NOT WARRANT THAT Software WILL BE FREE OF ERRORS AND YOU ACKNOWLEDGE THAT THE EXISTENCE OF ANY SUCH ERRORS DOES NOT CONSTITUTE A BREACH OF THIS AGREEMENT. TO THE EXTENT PERMITTED BY LAW LICENSOR AND LICENSOR'S AUTHORIZED REPRESENTATIVES EXPRESSLY DISCLAIM ALL WARRANTIES, EXPRESS OR IMPLIED, INCLUDING, BUT NOT LIMITED TO, THE IMPLIED WARRANTIES OF MERCHANTABILITY AND FITNESS FOR A PARTICULAR PURPOSE UNLESS OTHERWISE STATED HEREIN. LICENSOR AND LICENSOR'S AUTHORIZED REPRESENTATIVES DO NOT WARRANT THAT THE FUNCTIONS CONTAINED IN THE Software WILL MEET THE END-USER REQUIREMENTS OR THAT THE OPERATION OF THE Software WILL BE CORRECT. FURTHERMORE, LICENSOR AND LICENSOR'S AUTHORIZED REPRESENTATIVES DO NOT WARRANT OR MAKE ANY REPRESENTATIONS REGARDING THE USE OR THE RESULTS OF THE USE OF THE Software IN TERMS OF ITS CORRECTNESS, ACCURACY, RELIABILITY, OR OTHERWISE. NO ORAL OR WRITTEN INFORMATION OR ADVICE GIVEN BY LICENSOR AND LICENSOR'S AUTHORIZED REPRESENTATIVE SHALL CREATE A WARRANTY OR IN ANY WAY INCREASE THE SCOPE OF THIS WARRANTY. SHOULD THE Software PROVE DEFECTIVE IN YOUR TECHNOLOGY ENVIRONMENT, YOU ASSUME THE ENTIRE COST OF ALL NECESSARY SERVICING, REPAIR OR CORRECTION TO YOUR OWN TECHNOLOGY ENVIRONMENT.
10. Limitation of liability. TO THE MAXIMUM EXTENT PERMITTED BY LAW, LICENSOR AND LICENSOR'S AUTHORIZED REPRESENTATIVES SHALL NOT BE LIABLE FOR ANY INCIDENTAL OR CONSEQUENTIAL DAMAGES FOR BREACH OF ANY EXPRESS OR IMPLIED WARRANTY, BREACH OF CONTRACT, NEGLIGENCE, STRICT LIABILITY OR ANY OTHER LEGAL THEORY RELATED TO THE Software. SUCH DAMAGES INCLUDE, BUT ARE NOT LIMITED TO, LOSS OF PROFITS, LOSS OF REVENUE, LOSS OF DATA, LOSS OF USE OF THE PRODUCT OR ANY ASSOCIATED EQUIPMENT, DOWN TIME AND USER'S TIME, EVEN IF THE LICENSOR HAS BEEN ADVISED OF THE POSSIBILITY OF SUCH DAMAGES. IN ANY CASE, LICENSOR ENTIRE LIABILITY UNDER ANY PROVISION OF THIS AGREEMENT SHALL BE LIMITED TO THE AMOUNT ACTUALLY PAID IN RESPECT OF THE LICENSOR'S PRODUCTS PURCHASED BY THE END-USER PURSUANT TO A PURCHASE AGREEMENT.
11. Training, Maintenance and Support There is no entitlement to training, maintenance and support under this license unless otherwise specified in the Purchase Agreement or any other written agreement between the End-User and the Licensor. The End-User may provide the Licensor with details regarding any bug, defect or failure in the Software promptly and with no delay from such event; the End-User shall comply with the Licensor's request for information regarding bugs, defects or failures and furnish him with information, screenshots and try to reproduce such bugs, defects or failures upon Licensor's demand.



12. Expiration and Termination. The Licensor may terminate this Agreement for default by the End-User. This Agreement will also be automatically terminated upon the election of such by the Licensor or the official launch of the Software, whichever event comes first. Upon termination of this Agreement for any reason, the End-User shall promptly uninstall the Software on any UR's Products and Licensor's Products, computer, or server on which it has been installed, deliver to the Licensor all CDs, DVDs, magnetic tapes, cards, and other tangible items and materials embodying the Software, and return to the Licensor all copies thereof or destroy such copies and warrant in writing that all copies thereof have been destroyed. In the event of termination of this Agreement, all obligations of the parties under this Agreement due for performance on the date of termination shall survive the termination, and the party terminating shall not be liable to the other party for any damages arising out of the termination.
13. Miscellaneous.
 1. This Agreement constitutes the entire understanding and agreement between the Licensor and the End-User and replaces any prior agreement relating to the same subject matter.
 2. This Agreement shall be governed and construed in accordance with the laws of the province of Quebec and the federal laws of Canada applicable therein. Any legal action or proceeding between the Licensor and the End-User for any purpose concerning this Agreement or the parties' obligations hereunder shall be brought exclusively in a court of competent jurisdiction sitting in the judicial district of Trois-Rivières, Quebec.
 3. The Licensor's failure to insist upon or enforce strict performance of any provision of this Agreement shall not be construed as a waiver of any provision or right. Neither the course of conduct between the parties nor trade practice shall act to modify any provision of this Agreement.
 4. The Licensor may assign its rights and duties under this Agreement to any party at any time without notice to the End-User. The End-User may not assign this Agreement without the prior written consent of the Licensor.
 5. If any part of this Agreement is null, illegal or non-enforceable, this Agreement shall be interpreted as if this part was never part of this Agreement.
 6. The provisions of this Agreement are for the benefit of the Licensor and its officers, directors, employees, agents, licensors and suppliers. Each of these individuals or entities shall have the right to assert and enforce those provisions directly against the End-User on its own behalf. This Agreement is also for the benefit of, and binds, the End-User and its heirs, successors, legal representatives and permitted assigns.
 7. Any rights not expressly granted herein are reserved.
 8. The parties confirm that they have agreed that this Agreement and all related documents be drafted in English only. Les parties aux présentes confirment qu'elles ont accepté que la présente convention et tous les documents y afférents soient rédigés en anglais seulement.



4. Software

Info

Unless specified, all units in this section are in hexadecimal values.

4.1 Overview

Info

The operator can:

- Control the vacuum level (continuous vacuum when manual mode is set at 100%)
- Set the minimum vacuum level
- The automatic mode operation is set by default. The continuous operation mode can also be choose, when checked in the Advanced settings.
- Benefit from a security mode if air leakage is detected
- Benefit from energy saving with the automatic mode.
- Apply a timeout manually (ms) or benefit from an automatic timeout delay

4.1.1 Control using registers

The Vacuum Gripper has an internal memory that is shared with the robot controller. One part of the memory is for robot output (Gripper functionalities). The other part of the memory is for robot input (Gripper status). Two types of actions can thus be performed by the robot controller:

1. Write in the robot output registers to activate functionalities;
2. Read in the robot input registers to get the status of the Gripper.

The **Vacuum Gripper register mapping** section will map the different registers used to control the Gripper or to read its status. The **Robot output registers & functionalities** section will detail the output (write) register functions. The **Robot input registers & status** section will detail the input (read) register status. The figure below is a representation of the memory and the control logic of the Gripper.



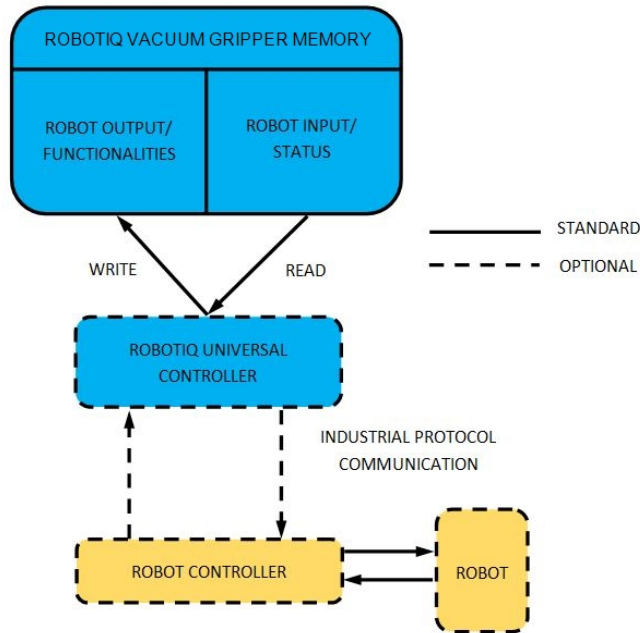

Fig. 4-1: Vacuum Gripper control logic overview

4.12. Control over Universal Robots package

Robotiq provides Universal Robots packages to be used with URCaps (require CB3.1 robot controller or later versions).

Please refer to the **Control over Universal Robots with URCap** section for instructions on how to use the Gripper URCap. This method will provide you with a Vacuum Gripper Toolbar to test and a Gripper node to program via the UR Command Window.



4.2. Vacuum Gripper register mapping

Caution

Byte numbering starts at zero.

Register	Robot Output/Functionality	Robot Input/Status
Byte 0	ACTION REQUEST	GRIPPER STATUS
Byte 1	RESERVED	GRIPPER STATUS
Byte 2	RESERVED	FAULT STATUS
Byte 3	MAX RELATIVE PRESSURE LEVEL REQUEST	MAX RELATIVE PRESSURE LEVEL REQUEST ECHO
Byte 4	GRIP TIMEOUT / RELEASE DELAY	ACTUAL RELATIVE PRESSURE
Byte 5	MINIMUM RELATIVE PRESSURE LEVEL REQUEST	RESERVED
Byte 6 to 15	RESERVED	RESERVED

Table 4-1: Registers of the Vacuum Gripper

4.3. Robot output registers & functionalities

Register: ACTION REQUEST

Address: Byte 0

Bits	7	6	5	4	3	2	1	0
Symbols	Reserved			rATR	rGTO	rMOD		rACT



rACT (Activate)

The rACT bit allows the Gripper to be operational.

- 0b0 - Clear Gripper fault status.
- 0b1 - Gripper is operational. Must stay 0x01 at all time during normal operation of the gripper.

rMOD Gripper mode

The rMOD bits are used to select the gripping mode.

- 0b00 - Automatic mode. The gripper will automatically detect the proper vacuum level, timeout/delay and hysteresis.
- 0b01 - Advanced mode. The user can set the desired minimum and maximum vacuum level and the time-out.
- 0b10 - Reserved
- 0b11 - Reserved

rGTO (Regulate)

The rGTO bit allow gripper to follow the desired vacuum parameters.

- 0b0 - Stop the vacuum generator; valves are in position to hold the workpiece.
- 0b1 - Follow the requested vacuum parameters in real time. When timeout is reached, rGTO must be re-asserted (Set to 0b0 then to 0b1)

rATR (Automatic release)

The rATR bit is used to release the object to ambient pressure (if possible) without any timeout. The rATR bit overrides all other commands excluding the activation bit (rACT). rACT must be at 0b1 during this action.

- 0b0 - Normal operation
- 0b1 - Open the valves without any timeout. After an automatic release, rACT must be re-asserted (rACT=0b0 then rACT=0b1).

Register: RESERVED

Address: Byte 1

Bits	7	6	5	4	3	2	1	0
Symbols	Reserved							

Register: RESERVED

Address: Byte 2

Bits	7	6	5	4	3	2	1	0
Symbols	Reserved							



Register: MAXIMUM VACUUM/PRESSURE REQUEST**Address: Byte 3**

Bits	7	6	5	4	3	2	1	0
Symbols	rPR							

rPR (Maximum Vacuum/Pressure request)

This register is used to set the target vacuum or pressure and is only valid in manual mode (rMOD=0x01).

$$rPR = 100 + P_{max}$$

Where:

P_{max} is the target maximum differential pressure relative to ambient in kPa.

- 0x00 (0d0) - Continuous grip. Vacuum generator always ON.
- 0x16 (0d22) - Grip to 78% of vacuum (Maximum device vacuum).
- 0x5A (0d90) - Grip to 10% of vacuum (Minimum device vacuum).
- 0x64 (0d100) - Passive release. Releasing to ambient pressure.
- 0x65 (0d101) - Active release. Releasing with minimum positive pressure.
- 0xFF (0d255) - Active release. Releasing with maximum positive pressure.

Example:

For a grip with 78% of vacuum level, use P_{max} = -78 kPa in the formula.

For a release with 155 kPa of positive air, use P_{max} = 155 kPa in the formula.

Register: GRIP TIMEOUT / RELEASE TIME**Address: Byte 4**

Bits	7	6	5	4	3	2	1	0
Symbols	rSP							

rSP (Action timeout)

When gripping (rPR ≤ 0d99), this register is used to set the time window (each integer being 100 milliseconds) prior to a gripping error. The vacuum generator will stop after the timeout period. Only valid if rMOD=0x01.

- 0x00 (0d0) - No timeout.
- 0x0A (0d10) - 1 sec timeout period.
- 0xFF (0d255) - 25.5 sec timeout period.



When releasing ($rPR \geq 0d100$), this register is used to set the time window (each integer being 100 milliseconds) prior to set the vacuum actuators in holding mode. Only valid if $rMOD=0x01$.

- 0x00 (0d0) - Vacuum holding state set when ambient pressure is detected.
- 0x01 (0d01) - Vacuum holding state set 100 msec after ambient pressure is detected.
- 0x0A (0d10) - Vacuum holding state set 1000 msec after ambient pressure is detected.

Register: MINIMUM VACUUM/PRESSURE REQUEST

Address: Byte 5

Bits	7	6	5	4	3	2	1	0
Symbols	rFR							

rFR (Minimum Vacuum/Pressure request)

This register is used to set the appropriate minimum acceptable vacuum/pressure on the workpiece. When the minimum vacuum level is reached, the object flag (gOBJ) will be set. Once the object is detected, the vacuum generator will keep the vacuum level in between the minimum and maximum vacuum level. Only valid if $rMOD=0x01$.

$$rFR = 100 + P_{min}$$

Where:

P_{min} is the target minimum differential pressure relative to ambient in kPa.

- 0x00 (0d0) - Object will be detected when vacuum level reaches 100% (This is impossible, so avoid using this value)
- 0x1E (0d30) - Object will be detected when vacuum level reaches 70%.
- 0x50 (0d80) - Object will be detected when vacuum level reaches 20%.
- >0x64 (>0d100) - Reserved value

Example:

For a grip with a maximum of 78% vacuum level and an object detection at 20% of vacuum level, use:

$$P_{max} = -78 \text{ kPa}$$

$$P_{min} = -20 \text{ kPa}$$

$$rFR = 100 + (-20) = 80$$

Warning

Setting the pressure tolerance too low might wear the product prematurely resulting in a shorter lifespan than expected.

The warranty of the product is defined as the number of grip/release valve cycles and not in terms of object grip/release cycles.



4.4. Robot input registers & status

Register: GRIPPER STATUS

Address: Byte 0

Bits	7	6	5	4	3	2	1	0
Symbols	gOBJ		gSTA		gGTO	gMOD		gACT

gACT (Activate echo)

The gACT bit is the echo of the rACT bit in the ACTION REQUEST register.

gMOD (Gripper mode echo)

The gMOD bits are the echo of the rMOD bits in the ACTION REQUEST register.

gGTO (Regulate echo)

The gGTO bit is the echo of the rGTO bit in the ACTION REQUEST register. Valid only if the vacuum/pressure is regulated, otherwise it returns 0x0.

gSTA (Activation status)

The rSTA bits indicates the status of the gripper activation sequence.

- 0b00 - Gripper is not activated.
- 0b11 - Gripper is operational.

gOBJ (Object status)

The gOBJ bits indicates the status of the object detection.

- 0b00 - Unknown object detection. Regulating towards requested vacuum/pressure.
- 0b01 - Object detected. Minimum vacuum value reached.
- 0b10 - Object detected. Maximum vacuum value reached.
- 0b11 - No object detected. Object loss, dropped or gripping timeout reached.

Register: GRIPPER STATUS EXTENSION

Address: Byte 1

Bits	7	6	5	4	3	2	1	0
Symbols	Reserved						gVAS	



gVAS (Vacuum actuator status)

The rVASbits indicates the status of the gripper actuators.

- 0b00 - Standby. Vacuum generator and valves deasserted (OFF).
- 0b01 - Gripping. Vacuum generator ON.
- 0b10 - Passive releasing. Releasing to ambient pressure.
- 0b11 - Active releasing. Releasing with positive pressure.

Register: FAULT STATUS

Address: Byte 2

Bits	7	6	5	4	3	2	1	0
Symbols	kFLT				gFLT			

gFLT (Gripper fault status)

The gFLT bits indicates priority, minor or major fault codes that are useful for troubleshooting. Fault LED (red) is present on the Gripper chassis, LED can be blue, red or both and be solid or blinking.

- **No fault**
 - 0x0 - No fault (LED is blue)
- **Priority faults (0x0 < gFLT <= 0x7) (LED is blue)**
 - 0x5 - Action delayed
 - 0x3 - Very porous material detected
 - 0x6 - Gripping timeout. rGTO must be re-asserted (rGTO=0 then rGTO=1) or one of the following parameters must be changed (rMOD, rPR, rSP, rFR).
 - 0x7 - The Activation bit not set. Activation bit must be set prior to action (rACT=1).
- **Minor faults (0x8 <= gFLT <= 0x9) (LED continuous red)**
 - 0x8 - Maximum operating temperature exceeded, wait for cool-down.
 - 0x9 - No communication during at least 1 second. This fault will only be returned once if the next valid communication is a “read command” of the FAULT STATUS register.
- **Major faults (0xA <= gFLT <= 0xF) (LED blinking red/blue) - Reset is required (rising edge on activation bit rACT required)**
 - 0xA - Under minimum operating voltage.
 - 0xB - Automatic release in progress (Vacuum/pressure detected).
 - 0xC - Internal fault; contact support@robotiq.com.
 - 0xF - Automatic release completed (Vacuum/pressure not detected)



Info

While booting, status LED will be solid blue/red.

kFLT

Please refer to the optional Robotiq Universal Controller manual (input registers & status).

Register: MAXIMUM VACUUM/PRESSURE LEVEL REQUEST ECHO

Address: Byte 3

Bits	7	6	5	4	3	2	1	0
Symbols	gPR							

gPR (Vacuum/Pressure request echo)

This register is the echo of the MAXIMUM VACUUM/PRESSURE LEVEL REQUEST register.

Register: ACTUAL VACUUM/PRESSURE

Address: Byte 4

Bits	7	6	5	4	3	2	1	0
Symbols	gPO							

gPO (Actual Vacuum/Pressure)

The gPO is the actual vacuum/pressure measured in the suction cups.

$P_{diff} = gPO - 100$. Where P_{diff} is the differential pressure relative to ambient in kPa.

- 0x00 (0d00) - Maximum vacuum ($P_{diff} \leq -100$ kPa).
- 0x64 (0d100) - No differential pressure ($P_{diff} = 0$ kPa).
- 0xFF (0d255) - Maximum pressure ($P_{diff} \geq 155$ kPa).



4.5. Gripper behavior

Workpiece gripping/releasing is performed by changing the values of the gripper input registers. While the control is very simple, some behaviors deserve a better explanation.

4.5.1 Control modes

The vacuum gripper can work in two different mode: the Automatic and Advanced options.

Automatic mode

The automatic mode is selected when `rMOD==0b00`. In this mode, the gripper will automatically detect the proper vacuum levels and timeout/delay required to grip or release the workpiece. Behavior of the automatic mode changes depending on the workpiece surface material, the suction cup condition and the firmware revision. This mode should be used when the user wants to make a quick test. If a constant behavior is needed, using the advanced mode is a more suitable option.

When gripping an object in the automatic mode, the Vacuum Gripper will:

1. Try to reach the maximum possible vacuum level for a maximum period of 2 seconds.
2. Automatically determine a desired minimum and maximum vacuum level in order to keep a good grip on the workpiece, if a vacuum level of more than 20% is detected and the level seems constant.
3. Set the object flag.
4. Vacuum generator will keep the vacuum level in between min and max until a release command is received.
5. Object lost/drop flag will be set if the vacuum level drops below 10% or if the vacuum level falls below the minimum vacuum level for more than 2 seconds.

When releasing an object in the automatic mode, the Vacuum Gripper will:

1. Open the release valve.
2. Object drop flag will be set when the vacuum level falls below 0.5%.
3. Release valve will be kept open for 1 second.



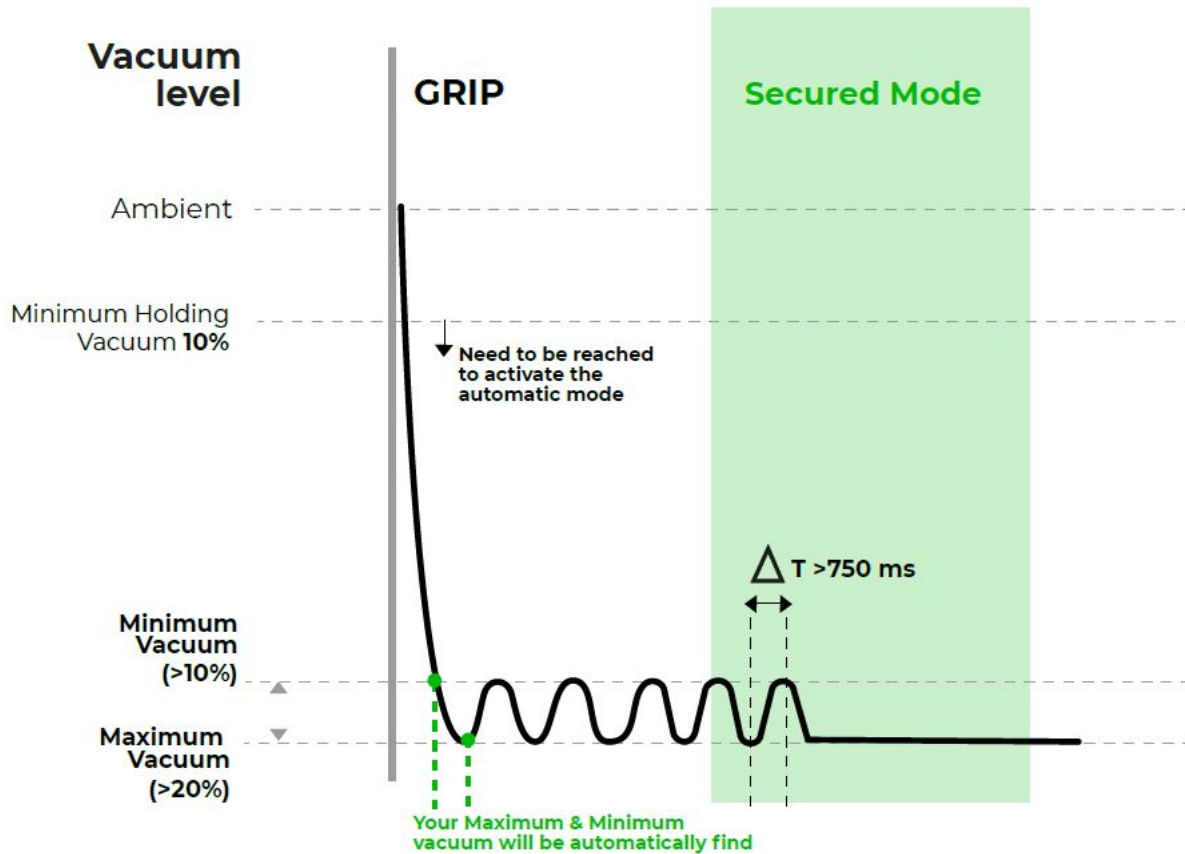

Fig. 4-2: Vacuum level vs time in the automatic mode

Advanced mode

The advanced mode is selected when $rMOD=0b01$. In this mode, the user can set the desired vacuum levels and timeout/delay required to grip/release the object. Behavior of the manual mode only depends on the maximum vacuum level, minimum vacuum level and the timeout/delay registers. This mode should be used when the user wants to have a constant production behavior.

When gripping an object in the manual mode, with the maximum vacuum level set below 100%, the Vacuum Gripper will:

1. Try to reach the desired maximum vacuum level for a maximum period of the desired timeout value.
2. If the desired maximum vacuum level is reached and the vacuum level is higher than 20%, object flag will be set to (gOBJ=0b10).
3. Vacuum generator will keep the vacuum level in between min and max until a release command is received. Object flag will toggle in between (gOBJ=0b01) and (gOBJ=0b10).
4. Object lost/drop flag will be set if the vacuum level drops below 10% or if the vacuum level falls below the desired minimum vacuum level for more than the desired timeout value.

When gripping an object in the manual mode with the maximum vacuum level set to 100%, the Vacuum Gripper will:

1. Continuously generate a vacuum
2. When the minimum vacuum level is reached, object flag will be set (gOBJ=0b01). Object flag (gOBJ=0b10) will never be set because 100% of vacuum level is impossible to reach.
3. Object lost/drop flag will be set if the vacuum level drops below 10% or if the vacuum level falls below the minimum vacuum level for more than the desired timeout value.

When releasing an object in the manual mode, the Vacuum Gripper will:



1. Open the release valve.
2. Object drop flag will be set when the vacuum level falls below 0.5%.
3. Release valve will be kept open for 1 second.

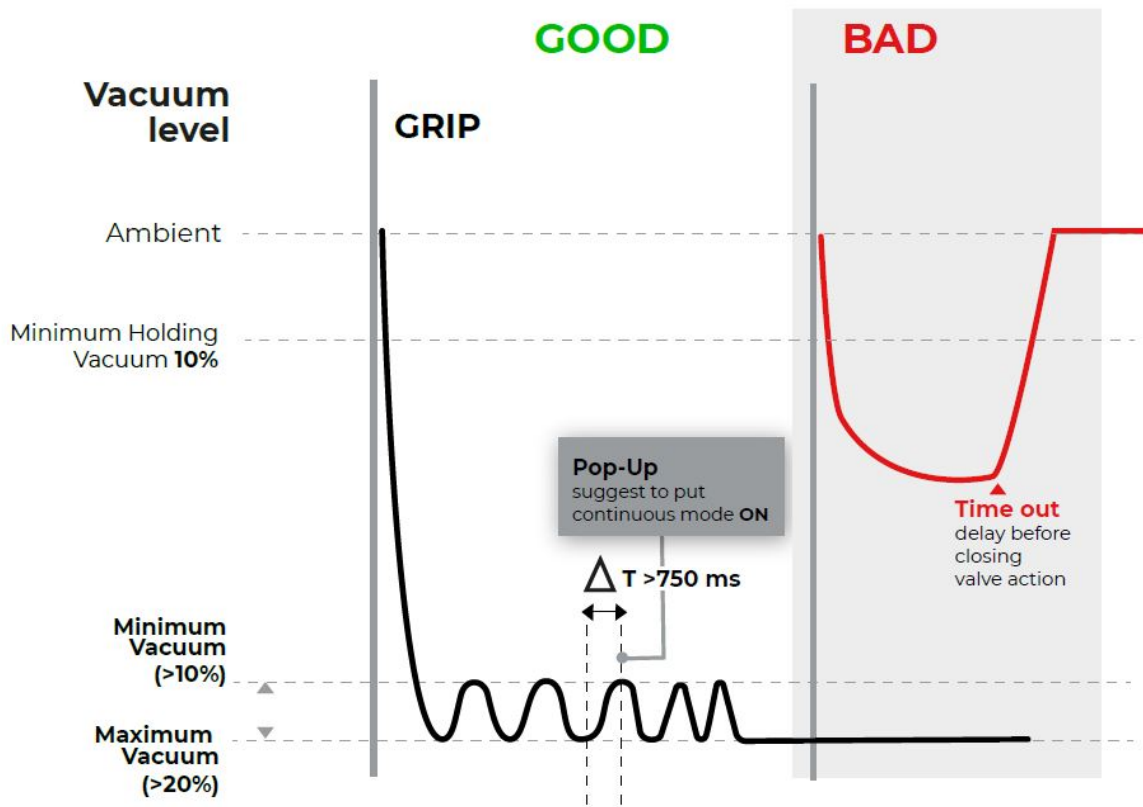

Fig. 4-3: Vacuum level vs time in the Advanced mode



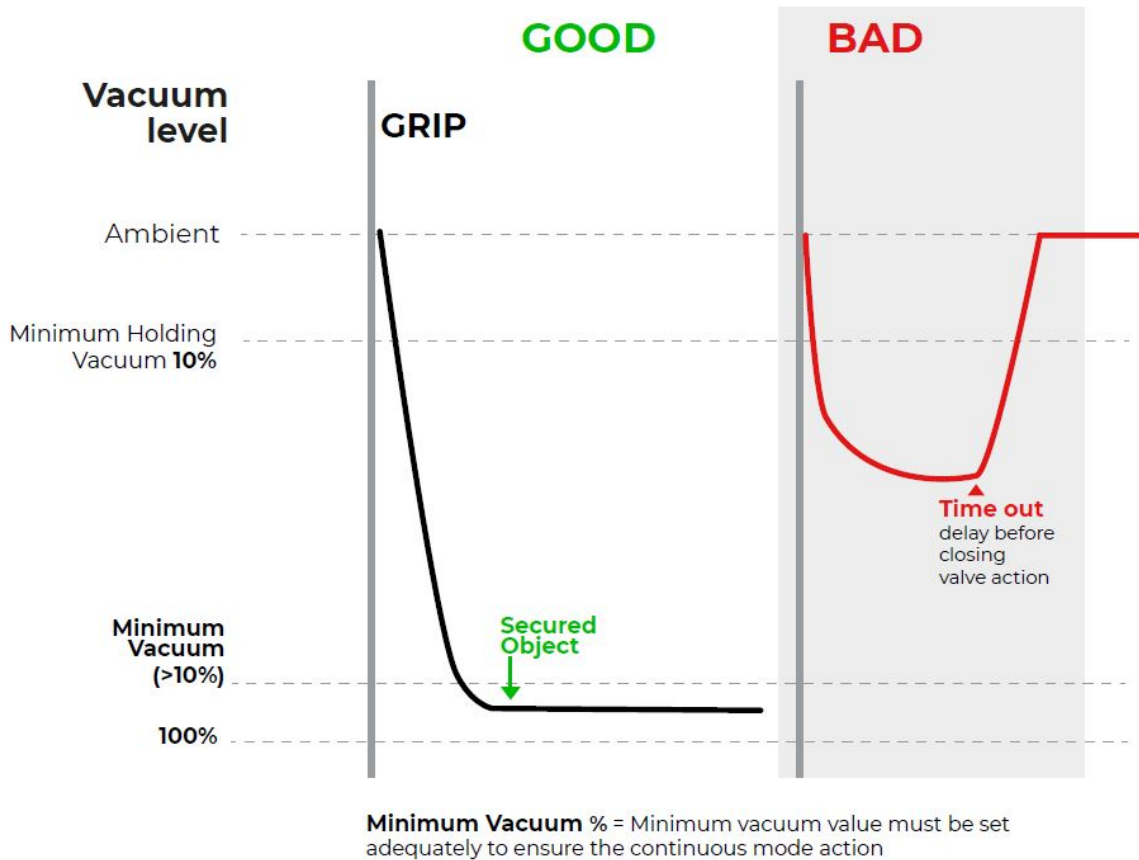

Fig. 4-4: Vacuum level vs time in the continuous mode

Very porous material detection

When a very porous material is detected or when the suction wears out, the Vacuum Gripper will detect it and react according to the gripper mode. When this condition occurs, it is important to find the underlying reason because it will make the vacuum generator start and stop very rapidly. This can lead to a premature wear of the gripper internal mechanics.

- In **automatic mode**, no fault will be set, but the gripper will continuously run the vacuum generator until a release command is received.
- In **advanced mode**, a fault flag will be set (gFLT=0x3) and the gripper will continue to run with the desired settings.

Object lost/ drop behavior

When an object is lost or dropped, the gripper will set an object flag (gOBJ=0b11). This means that the vacuum level has fallen below 10% or below the minimum desired vacuum level for a the desired timeout value.

Object secured behavior

As soon as the grip command is received by the gripper:

1. The unknown object flag will be set (gOBJ=0b00).
2. If the vacuum level reaches the desired maximum vacuum level, the object secure to max flag will be set (gOBJ=0b10).



- The vacuum generator will stop until the vacuum reach the desired minimum vacuum level.
- The object secured to min flag will be set (gOBJ=0b01) and the vacuum generator will try to reach the maximum vacuum again.

Object not detected behavior

When a grip command is received, the gripper will use the desired timeout value as a maximum period of time to detect an object. When no object is detected after the timeout value, the timeout flag will be set (gFLT=0x6). To retry the same grip command, the regulate bit needs to be re-asserted (rGTO=0b0, then rGTO=0b1). If new gripping settings are received (rMOD, rPR, rFR, rSP), there is no need to re-assert the regulate bit.

Object release delay

When the release command is received, the vacuum gripper will open the release valve in order to let air enter the suction cups. Once the pressure inside the suction cup is equal or greater than the ambient pressure, the gripper will set the no object flag (gOBJ=0b11). The robot will then move away from the workpiece. Depending on the suction type, this motion might create a new vacuum inside the suction cups. Therefore, the user can set the distance for the robot to move away from the workpiece. Once this distance is reached, the Vacuum Gripper valve will close.

Emergency stop behavior

Depending on the robot, the behavior might be different when pushing an emergency stop. If the user wants to ensure a good grip even in emergency stop, the vacuum gripper must be connected to a supply source that will not drop when pushing the emergency stop. As long as the gripper is supplied, it will always try to keep the workpiece, even if the communication is stopped with the robot.

4.6. Control logic

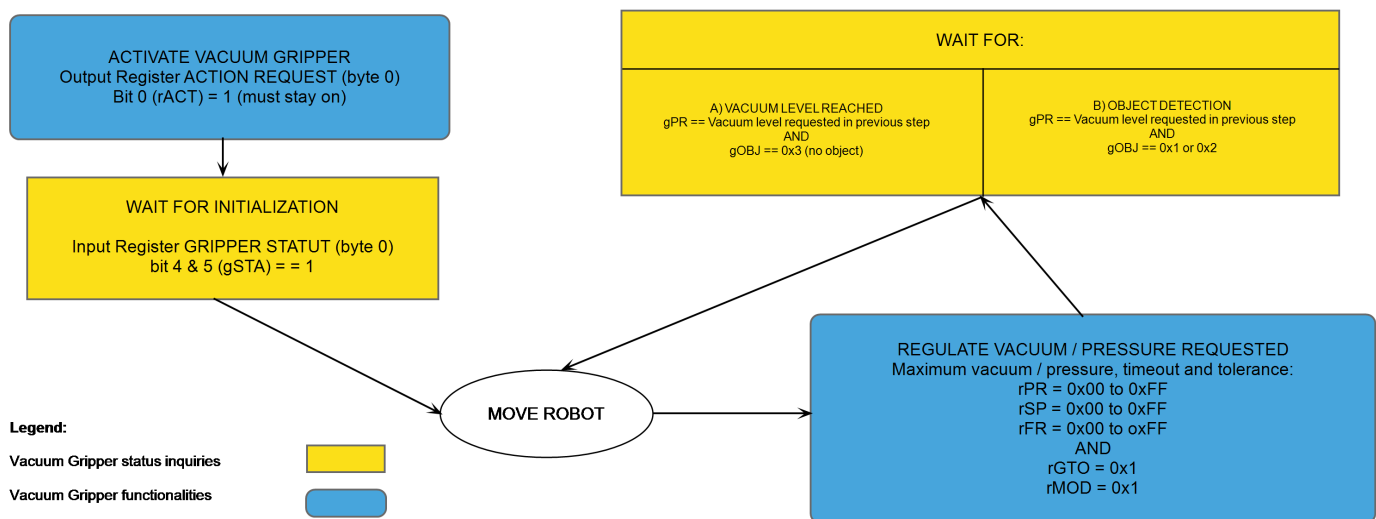

Fig. 4-5: Example of the Vacuum Gripper control logic with associated registers.

4.7. Modbus RTU communication

The Vacuum Gripper can be controlled by Modbus RTU over RS485. This section is intended to provide guidelines for setting up a Modbus master that will adequately communicate with the Gripper.

For a general introduction to Modbus RTU and for details regarding the CRC algorithm, the reader is invited to read the Modbus over serial line specification and implementation guide available at: http://www.modbus.org/docs/Modbus_over_serial_line_V1_02.pdf.

For debugging purposes, the reader is also invited to download one of many free Modbus master such as the CAS Modbus Scanner from Chipkin Automation Systems available at: <http://www.store.chipkin.com/products/tools/cas-modbus-scanner>.



Info

Modbus RTU is a communication protocol based on a Big Endian byte order. Therefore, the 16-bit register addresses are transmitted with the most significant byte first. However, the data port is, in the case of Robotiq products, based on the Little Endian byte order. As such, the data parts of Modbus RTU messages are sent with the less significant byte first.

Tip

Modbus RTU specifications and details can be found at www.modbus.org.

4.7.1 Connection setup

The following table describes the connection requirements for controlling the Gripper using the Modbus RTU protocol.

Propriety	VALUE
Physical interface	RS-485
Baud rate	1.2KBps to 10500KBps; Default:115.2 KBps
Data bits	8 bits
Parity	None, Odd, Even; Default: None
Stop bit	1 or 2 bit; Default: 1 bit
Other Modbus functions	FC3, FC4, FC6, FC16, FC23,
Exception responses	0x03 (Illegal Data Value)
Slave ID	1 to 9; Default: 9
Robot output/Gripper input registers	1000 to 1007
Robot input/Gripper output registers	2000 to 2007

Table 4-2: Modbus RTU connection setup for the Vacuum Gripper

4.8. Control over Universal Robots with URCap

The URCap package contains several features to program and control the Vacuum Gripper. The package comprises:

- The Vacuum Gripper Toolbar: automatically installed with the URCap package. It allows to test the vacuum distribution. It is a great tool to try gripping workpieces while programming.
- The Vacuum node: The URCap package includes a node that is used to add and edit a Vacuum Gripper command. The node can make the device grip a workpiece, release a workpiece, set the vacuum distribution level, apply a manual timeout, and establish a shut off distance.



MainWindow

Connection View Help

Simple Control Device Information Modbus RTU Parameters

Vacuum Controls

- Activate
- Go to Request
- Auto-release

Vacuum Mode

Basic Mode Advanced Mode

Grip Release

Vacuum State: Standby

Advanced Mode Controls

Grip

Vacuum Level Ma /100

Vacuum Level Mir /100

Grip Timeout second(s)

Release

Pressure (KPa) /255

Release Time second(s)

Vacuum Feedback

EPick



Object Detection

Actual Vacuum Level

No Fault

Vacuum

Vacuum Level (%)

0 20 40 60 80 100

Connected to COM4.

© 2011-2019 Robotiq. All rights reserved.

MainWindow

Connection View Help

Simple Control Device Information Modbus RTU Parameters

Vacuum Controls

- Activate
- Go to Request
- Auto-release

Vacuum Mode

Basic Mode Advanced Mode

Grip Release

Vacuum State: Standby

Advanced Mode Controls

Grip

Vacuum Level Ma /100

Vacuum Level Mir /100

Grip Timeout second(s)

Release

Pressure (KPa) /255

Release Time second(s)

Vacuum Feedback

AirPick



Object Detection

Actual Vacuum Level

No Fault

Vacuum

Vacuum Level (%)

0 20 40 60 80 100

Connected to COM4.

© 2011-2019 Robotiq. All rights reserved.



4.8.1 Vacuum Gripper Scan

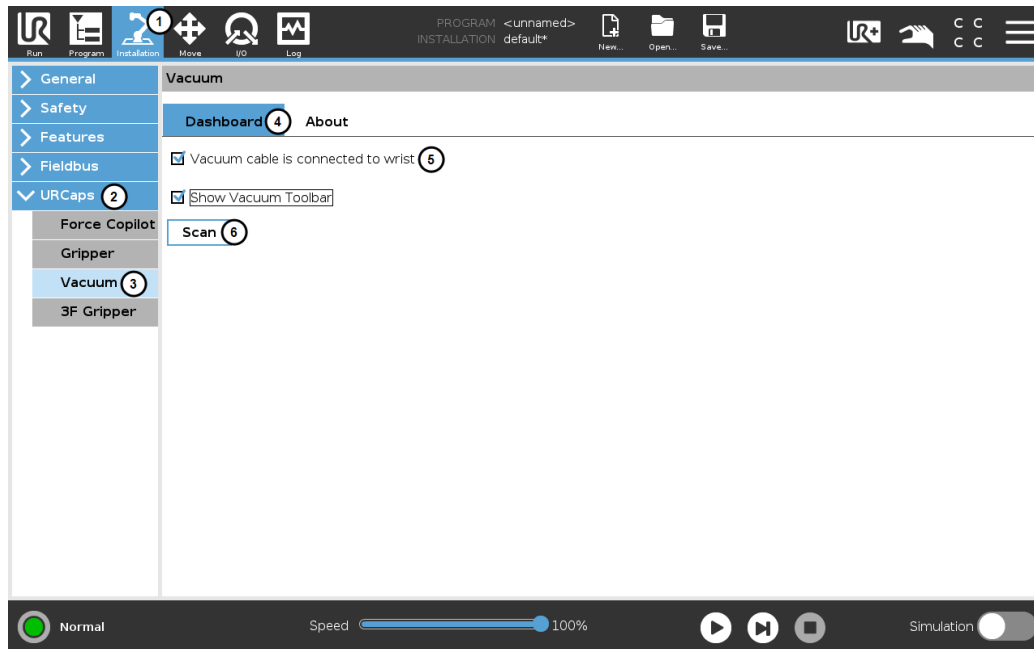

Fig. 4-6: Vacuum gripper scan

1. On the teach pendant, tap the **Installation** button.
2. Select **URCaps** in the navigation pane on the left.
3. Tap the **Vacuum** button.
4. Tap the **Dashboard** button.
5. Check the boxes.
6. Tap the **Scan** button.

Tip

The user can show and hide the Vacuum Gripper Toolbar by respectively ticking and unchecking the **Show Vacuum Toolbar** box.



4.8.2. Vacuum Gripper Toolbar

Overview

The Vacuum Gripper Toolbar is used to test the Gripper.

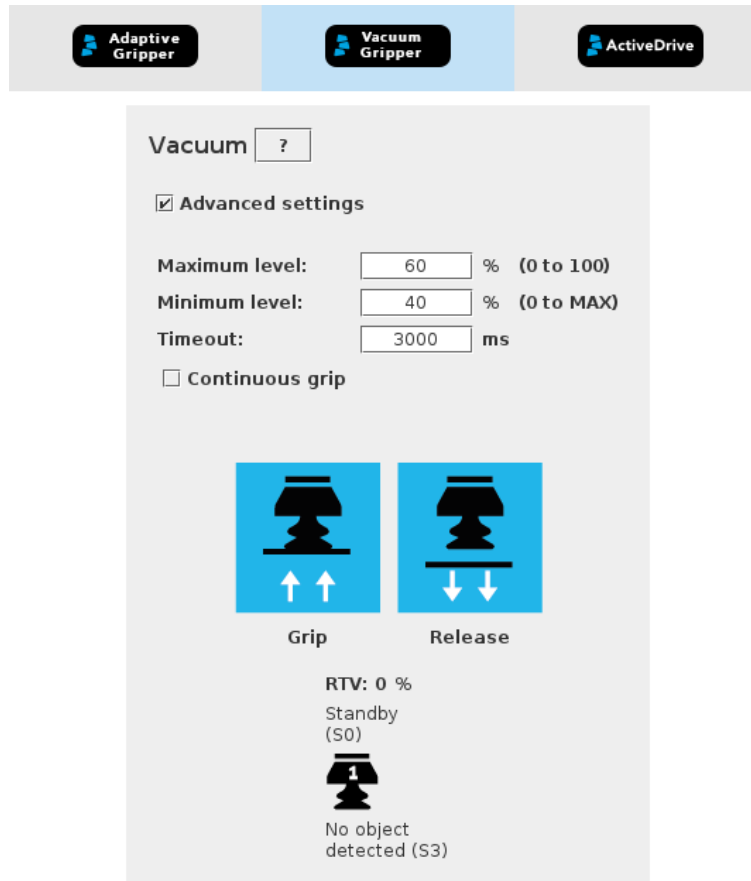



Fig. 4-7: Vacuum Gripper Toolbar

Features

Functionality name	Description
Advanced settings	Manual mode selector: Allows the user to set the maximum/minimum vacuum distribution levels, the timeout as well as the continuous mode . This mode allows a complete customization of the vacuum distribution to meet the user's specific application needs.
Maximum	Maximum vacuum distribution level. When this value is reached, the vacuum gripper stops the suction. Once the vacuum level reaches the minimum value, the suction will start again.
Minimum	Minimum vacuum distribution level. The vacuum gripper will start the suction once the vacuum level reaches this value, which is the one considered by the program to detect the object or not.
Grip	Performs a Grip test corresponding to the Grip mode selected.
Release	Performs a Release test corresponding to the Grip mode selected



Functionality name	Description
Timeout	Period after which a gripper error is generated. A 0 means that there is no timeout.
Continuous grip	Allows the vacuum gripper to perform suction while it moves an object from one place to an other.
Help 	Opens an informational pop-up to provide information to the user regarding the Gripper status and the Object status.

4.8.3. Vacuum Gripper node

To add and edit a Vacuum Gripper node inside your robot program, follow these steps:

1. On the teach pendant, at the top of the screen, tap the **New** icon to create a program or the **Open** icon to load a program.
2. Select **Program**. The Program window will display.
3. Tap the **URCaps** menu in the navigation pane on the left.
4. Tap the **Vacuum** button.
5. Select the node in the robot program and tap the **Command** tab.

Command window

The Command window shows the requested action parameters for the Vacuum Gripper node.

Info

Since the Automatic mode establishes the parameters in real time depending (among other factors) on the Gripper behavior and workpiece material, the Manual mode will mainly be documented.



Grip Command

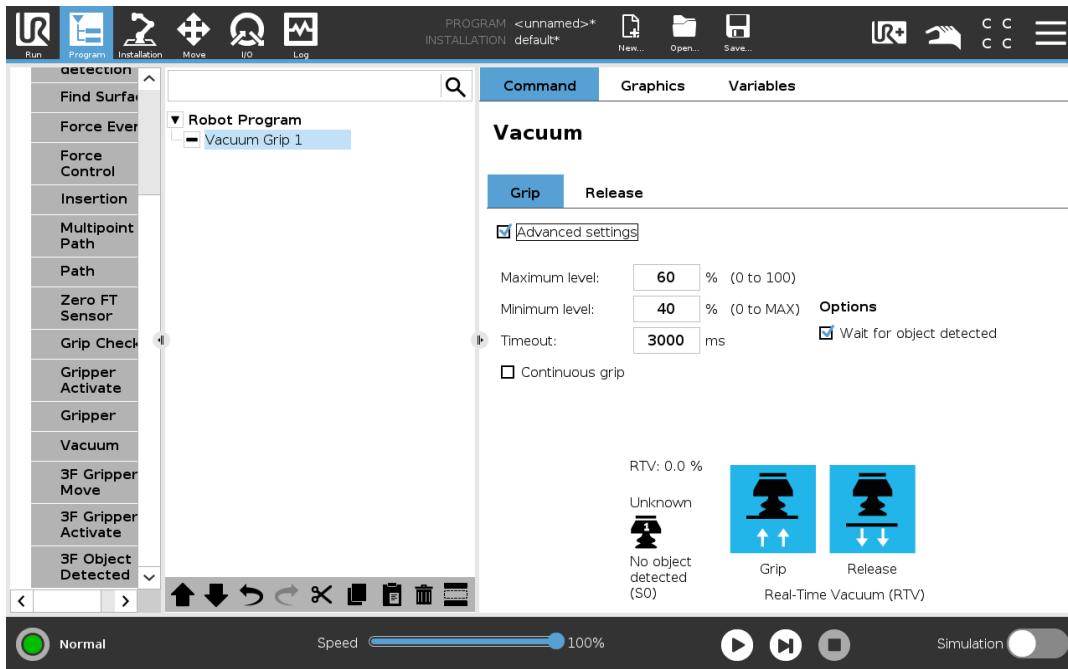

Fig. 4-8: Command window with Vacuum Gripper node - Grip node

- In the **Command** window, tap the **Grip** tile
- Tap the Advanced settings checkbox
- Tap the textbox next to Maximum level and use the numpad to enter a value between 0% and 100%
- Tap the textbox next to Minimum level and use the numpad to enter a value between 0% and the maximum vacuum level
- Tap the textbox next to Timeout and use the numpad to enter a value between 0 and 25,500 ms.
- The user can program using the object detection feature by ticking the **Wait for object detected**.



Functionality name	Description
Release	Toggles to the Release mode.
Advanced Settings	Manual mode selector: allows the user to set the maximum/minimum vacuum distribution levels, the timeout as well as the continuous mode . This mode allows a complete customization of the vacuum distribution to meet the user's specific application needs.
Maximum Level	Maximum vacuum distribution level. The vacuum gripper stops the suction at the reach of this value. The suction will start again when the vacuum level will reach the minimum value.
Minimum Level	Minimum vacuum distribution level. The vacuum gripper will start the suction once the vacuum level reaches this value.
Timeout	Period after which a gripper error is generated. A 0 means that there is no timeout.
Node test: Grip and Release button	Performs a Grip or Release test corresponding to the Grip mode selected.
Wait for object detected	Option enabling the Gripper to wait for an object detection before executing the next command in the program.
Continuous grip	Allows the vacuum gripper to perform suction while it moves an object from one place to another.

Release Command

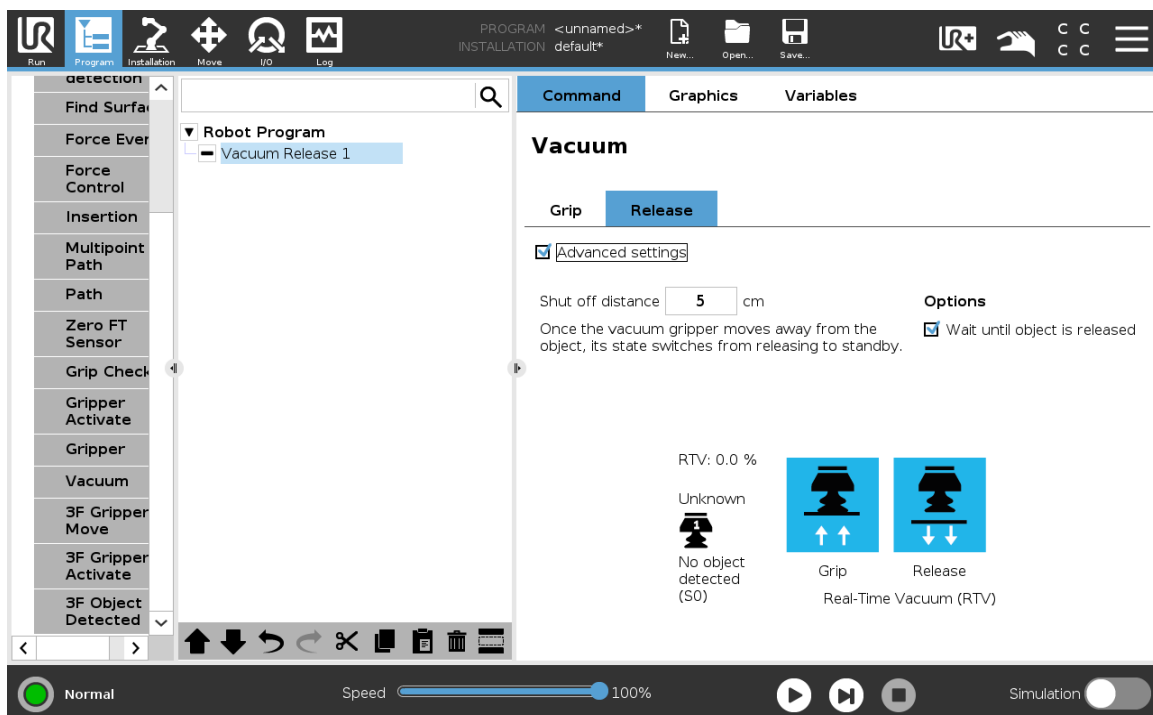

Fig. 4-9: Command window with Vacuum Gripper node - Release mode



- In the **Command** window, tap the **Release** tile.
- Tap the Advanced settings checkbox.
- Tap the textbox next to Shut off distance and use the numpad to enter a value indicating the travel distance at which the pump will stop distributing the pressure after a Release command.
- The user can program using the object detection feature by ticking the **Wait until object is released** in the Options.

Features

Functionality name	Description
Grip	Toggles to the Grip mode.
Advanced settings	Manual mode selector: allows the user to set the Shut off distance parameter.
Shut off distance	Closes the pump valves following a Gripper travel over a certain distance.
Node test: Grip and Release button	Minimum vacuum distribution level. The vacuum gripper will start the suction once the vacuum level reaches this value.
Wait until object is released	Option enabling the Gripper to wait until it does not detect an object anymore before executing the next command in the program

Advanced Vacuum Gripper Functions

The use of Gripper URcaps nodes allows the Vacuum Gripper to grip and release. The advanced functions supports multiple vacuum grippers and some of them are only available through UR Script commands. Also note that the value of the gripper socket can be 1, 2, 3 or 4.

Functionality name	Description
<code>rq_vacuum_release(advanced_mode, shutoff_distance_cm, wait_for_object_released, gripper_socket)</code>	Allows the Vacuum Gripper to grip an object. The default values are : advanced_mode=False, shutoff_distance_cm=5, wait_for_object_released=True, gripper_socket=" 1"
<code>rq_vacuum_grip(advanced_mode, maximum_vacuum, minimum_vacuum, timeout_ms, wait_for_object_detected, gripper_socket)</code>	Allows the Vacuum Gripper to release an object. The default values are : advanced_mode=False, maximum_vacuum=60, minimum_vacuum=40, timeout_ms=3000, wait_for_object_detected=True, gripper_socket=" 1"



rq_is_vacuum_obj_detected (gripper_socket)	Returns True if the Vacuum Gripper has detected an object. Returns False if Vacuum Gripper has not detected an object. Useful for verifying that an object has been picked correctly before going to the next step.
rq_set_gripper_max_cur(current_mA, gripperId)	Sets the Vacuum Gripper maximum supply current in mA.



5. User Interface

Visit support.robotiq.com to get the latest installer of the Robotiq User Interface along with appropriate documentation.

See the [instruction manual of the Robotiq User Interface](#) for more details.



6. Specifications

Caution

This manual uses the metric system, unless specified, **all dimensions are in millimeters.**

The following subsections provide data on the various specifications for the Robotiq EPick Gripper.

- Section 6.1 lists the technical dimensions of the Gripper
 - Dimensions for custom (blank) coupling
 - Dimensions of all available couplings
- Section 6.2 presents the mechanical specifications of the Gripper.
- Section 6.3 gives electrical specifications for the Gripper.

6.1 Technical dimensions

6.1.1 Gripper

The figure below represents the Gripper's dimensions.



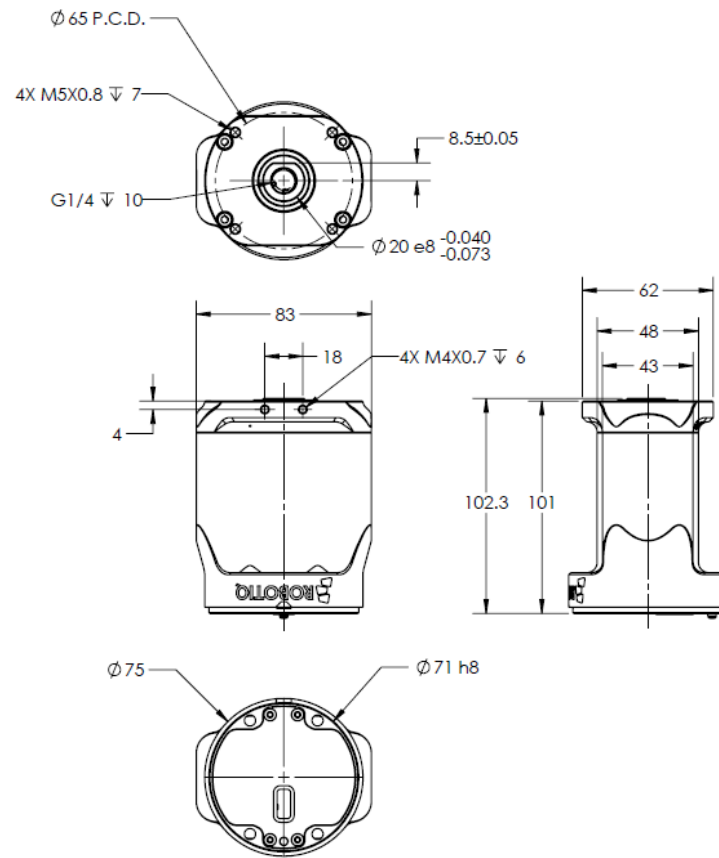

Fig. 6-1: EPick general dimensions



6.12. Suction Cup System

The figures below represent the dimensions of the components of the suction cup systems.

Manifold

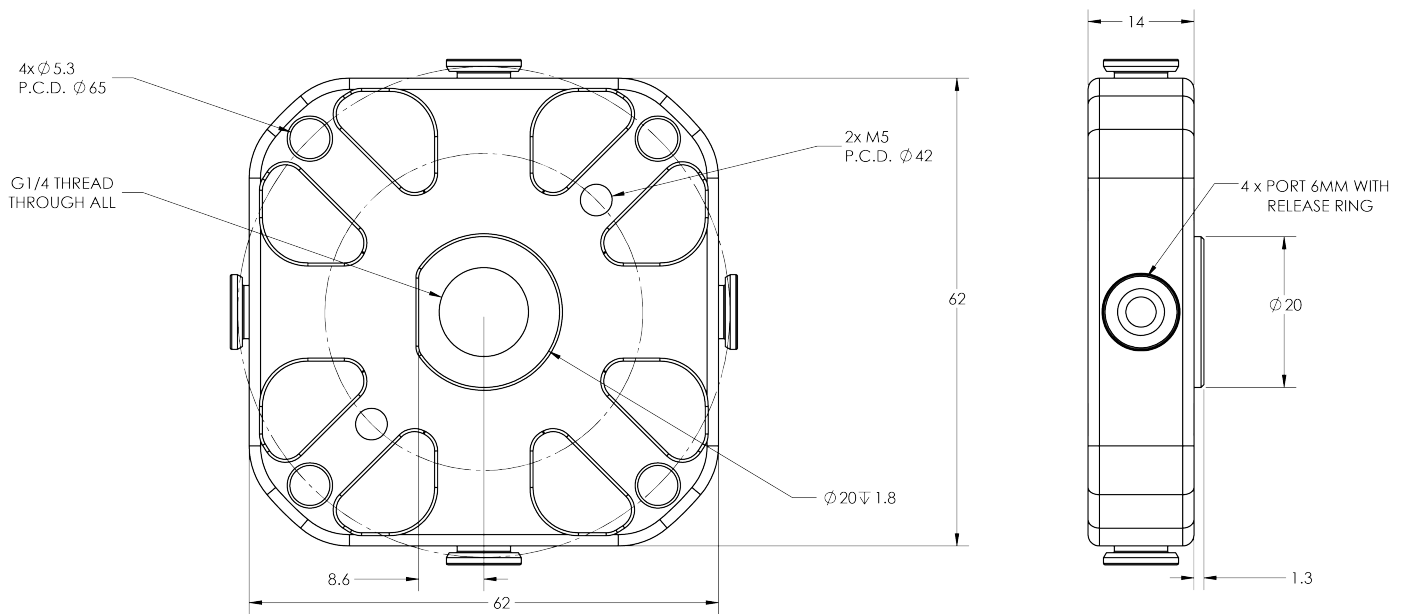
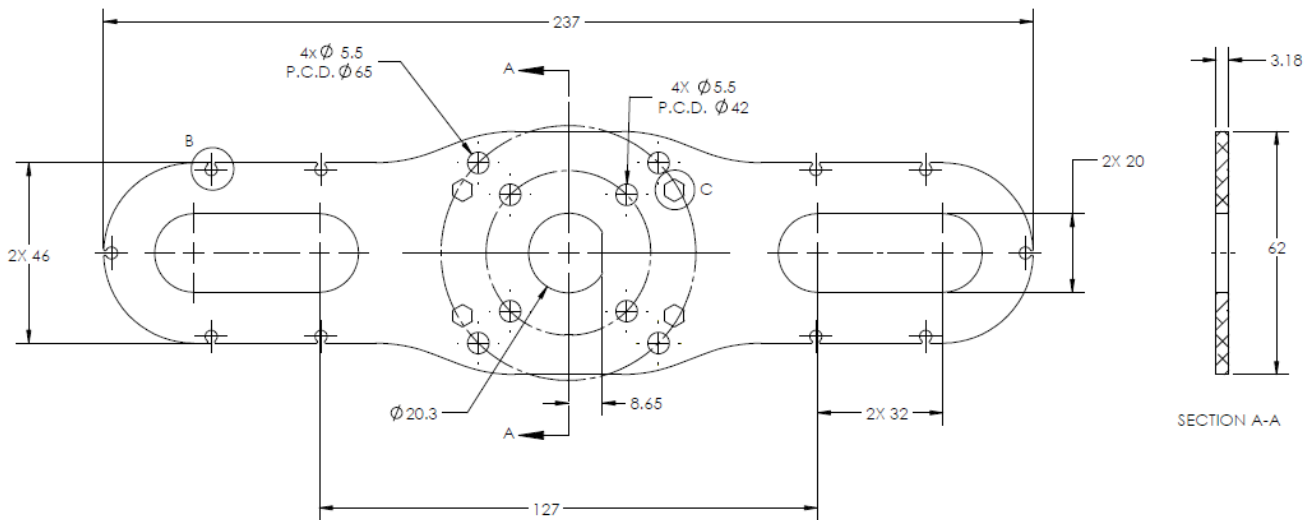
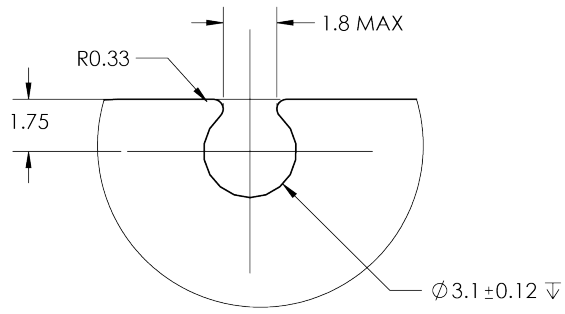

Fig. 6-2: Manifold general dimensions

Bracket for 2 suction cups





DETAIL B

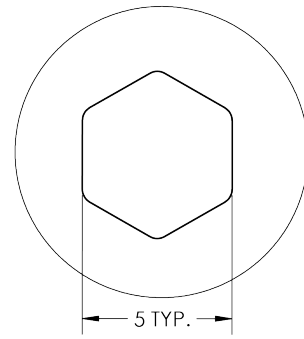

DETAIL C

Fig. 6-3: Two air nodes bracket's dimensions

Bracket for 4 suction cups

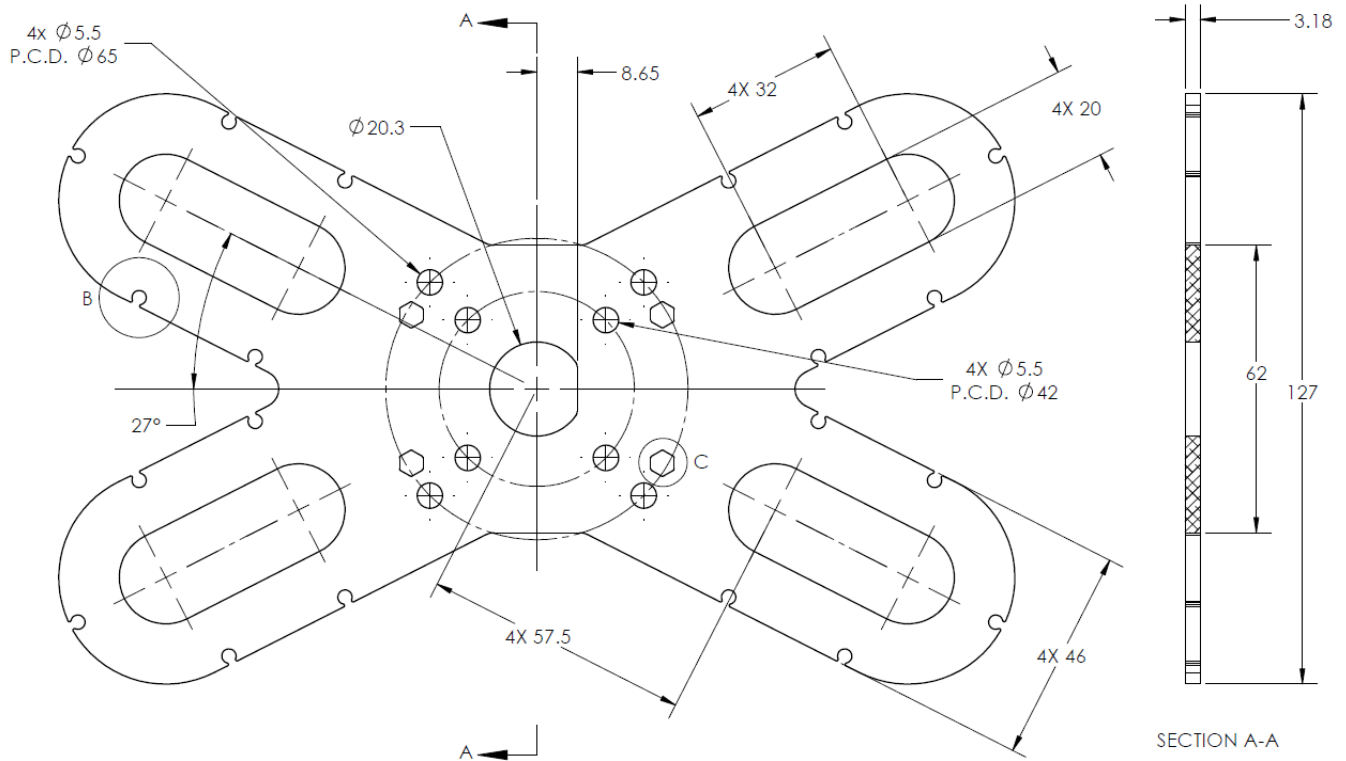

SECTION A-A



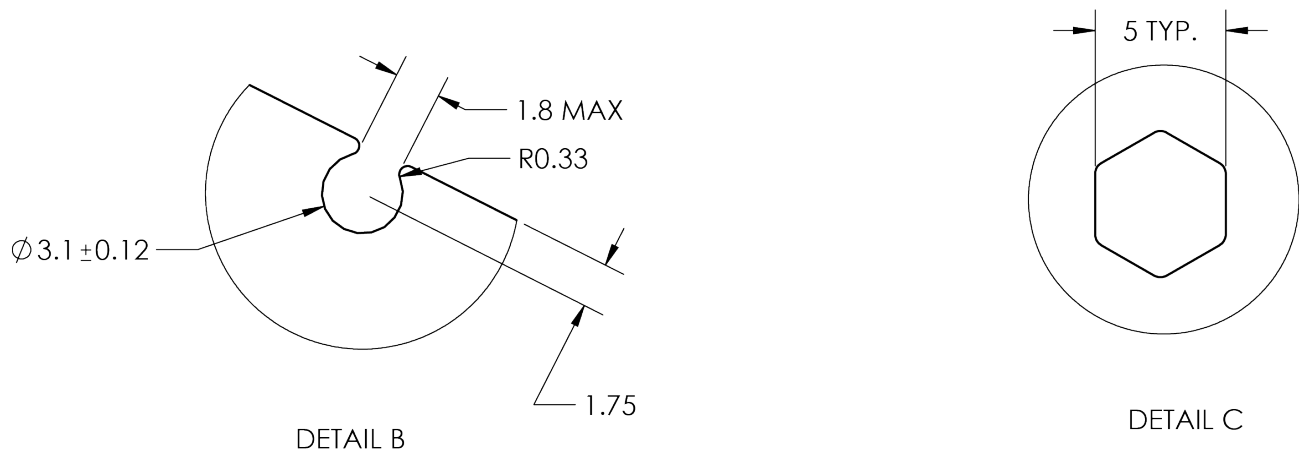

Fig. 6-4: Four air nodes bracket's dimensions

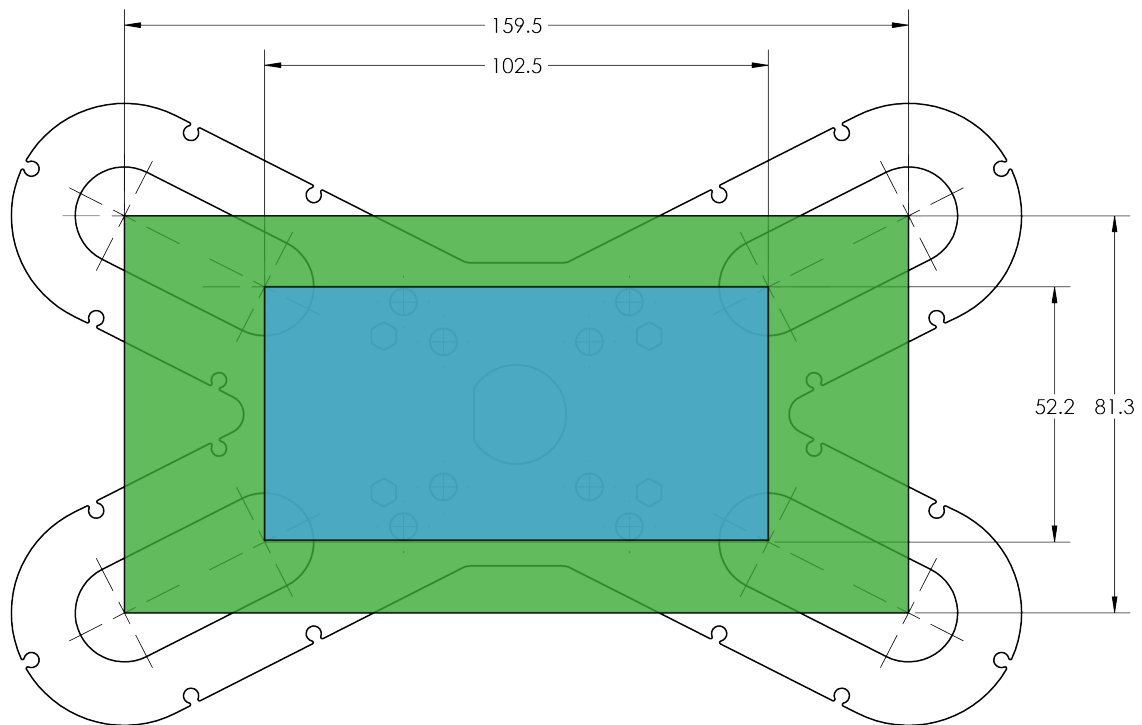

Fig. 6-5: Minimum and maximum arrangement possibilities of the air nodes position.

6.13. Air nodes

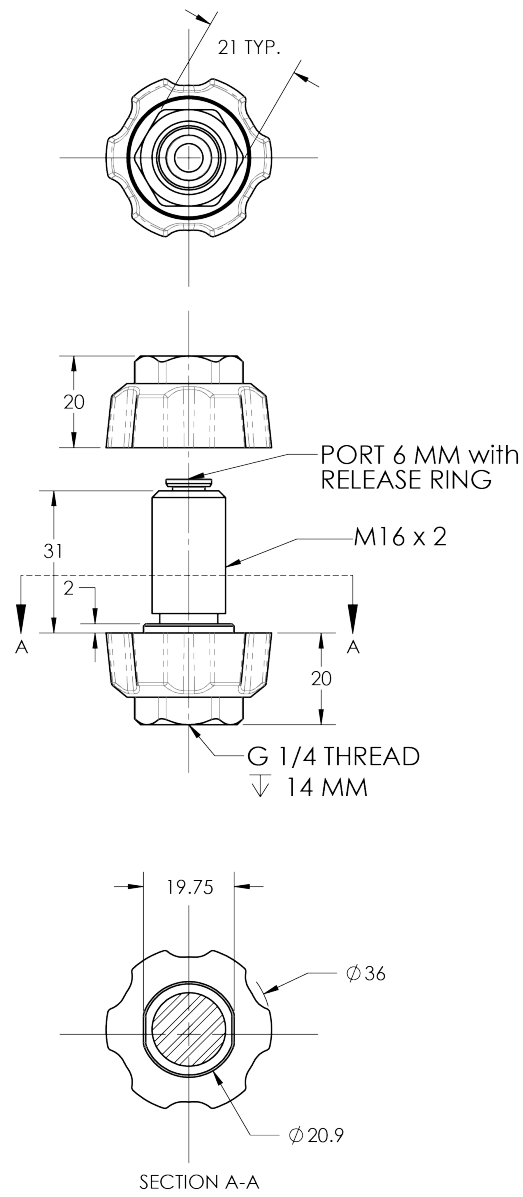

Fig. 6-6: Air nodes dimensions



6.14. Couplings

Operating the Vacuum Gripper requires a coupling provided by Robotiq. The coupling is mandatory since it integrates electronics and electrical contacts.

Blank coupling

Below are the dimensions of the blank coupling, **AGC-CPL-BLANK-002** (refer to the **Spare Parts, Kits and Accessories** section), available to create a custom bolt pattern. Blue section can be fully customized (holes can be placed in any part of this section) while the grey section can only be worked to a depth of 3 mm.

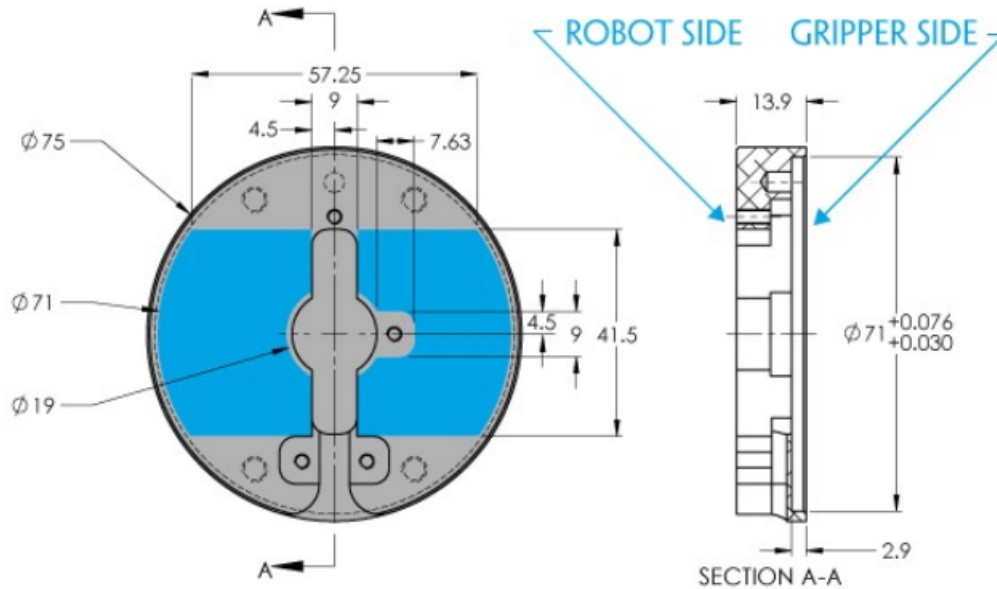

- FULLY CUSTOMIZABLE AREA
- CUSTOMIZABLE MAXIMUM DEPTH 3 MM AREA

Fig. 6-7: Workable area dimensions of blank coupling AGC-CPL-BLANK-002



Coupling for ISO 9409-1-50-4-M6

Bolt pattern for coupling **GRP-CPL-062** (refer to the **Spare Parts, Kits and Accessories** section) is compatible with :

- 50 mm pitch circle diameter :
- (4) M6-1.0 low head socket cap screw clearance
- (1) M6 indexing pin
- ISO 9409-1 standard 50-4-M6

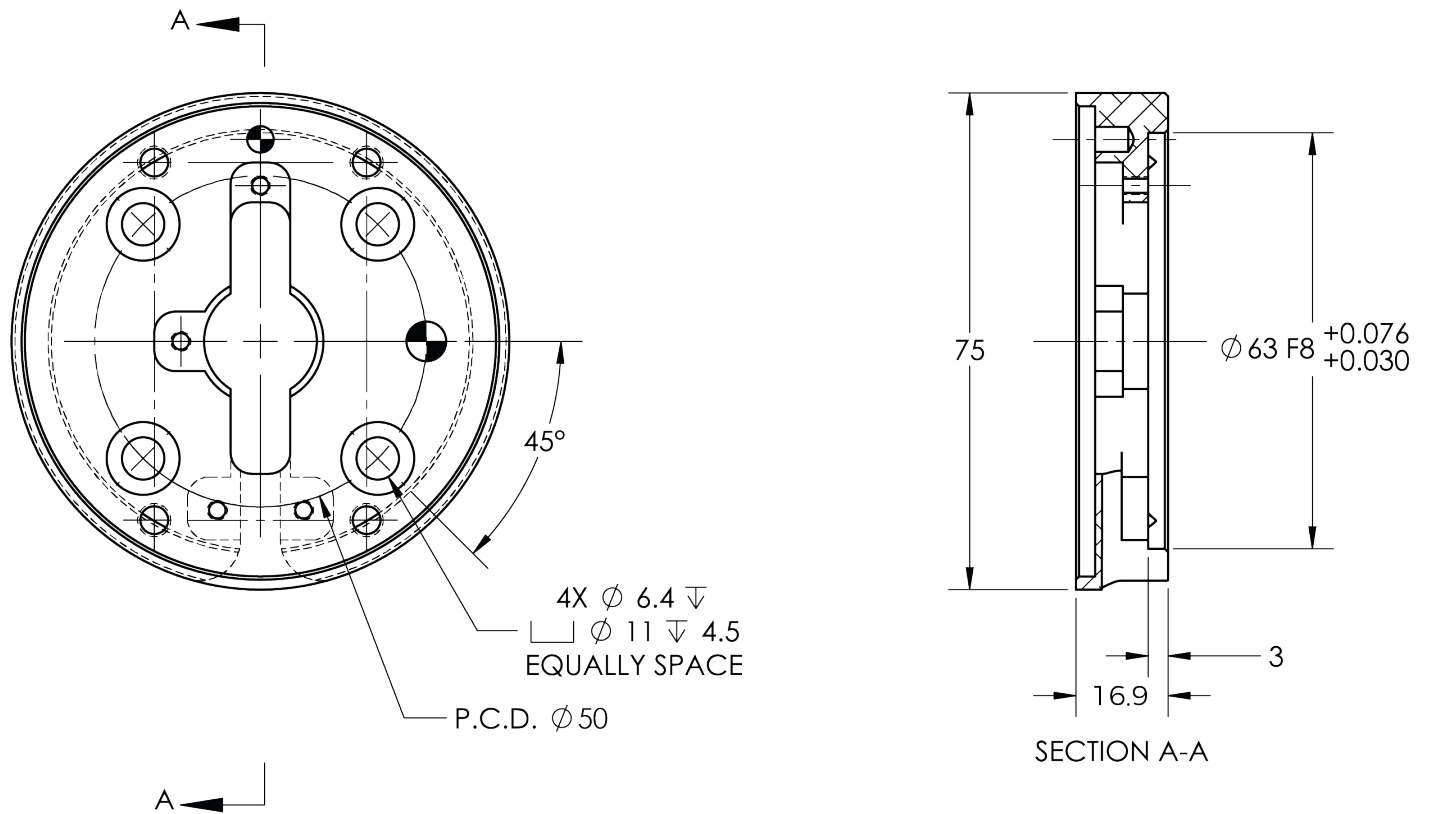

Fig. 6-8: Coupling for ISO 9409-1-50-4-M6.



Coupling for ISO 9409-1-315-4-M5

Bolt pattern for coupling **GRP-CPL-063** (refer to the **Spare Parts, Kits and Accessories** section) is compatible with :

- 31.5 mm pitch circle diameter :
 - (4) M5-0.8 low head socket cap screw clearance
 - (1) M5 indexing pin
- ISO 9409-1 standard 31.5-4-M5

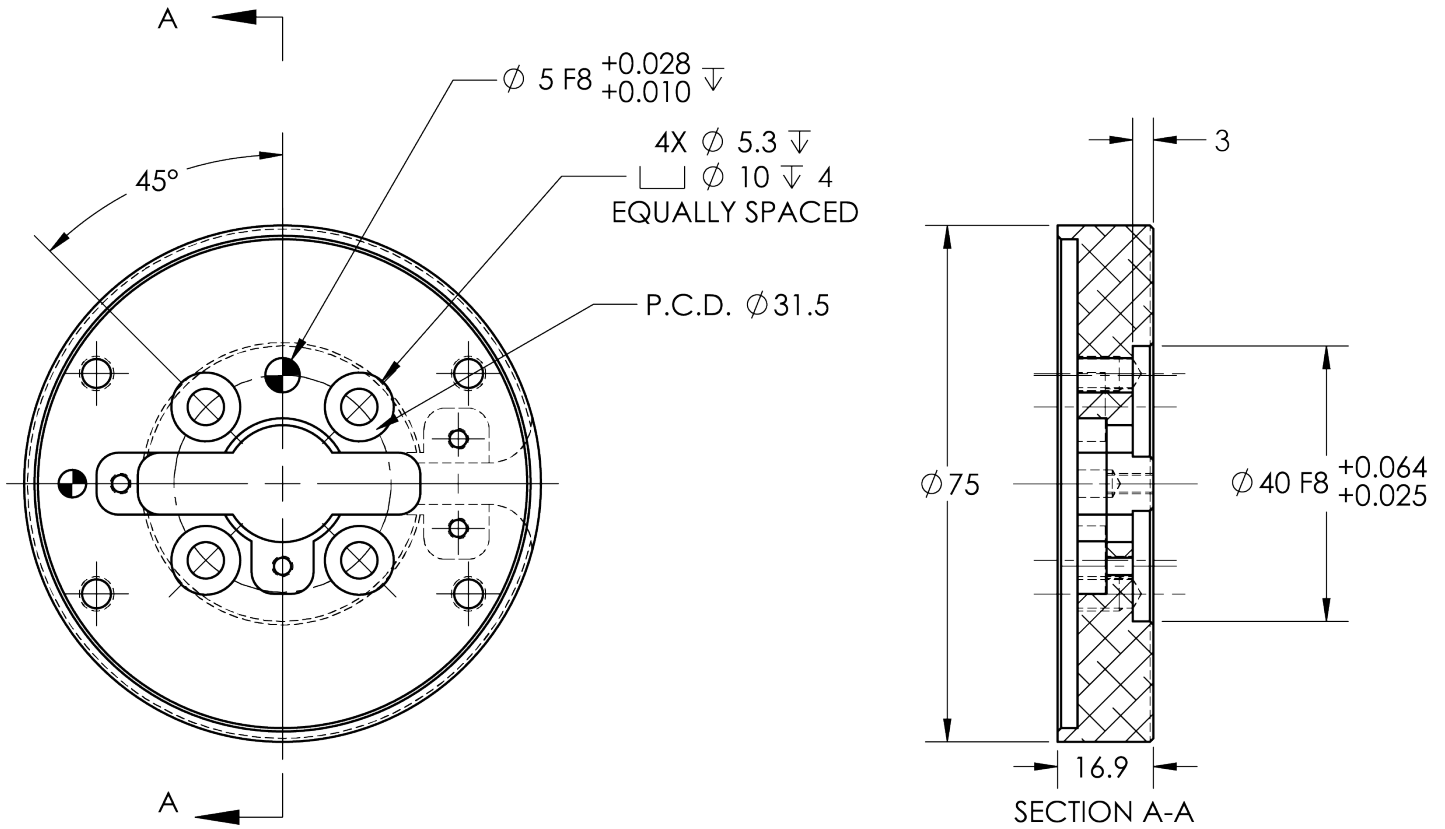

Fig. 6-9: Coupling for ISO 9409-1-31.5-4-M5.



Coupling for ISO 9409-1-40-4-M6

Bolt pattern for coupling **GRP-CPL-064** (refer to the **Spare Parts, Kits and Accessories** section) is compatible with :

- 40 mm pitch circle diameter :
- (4) M6-1.0 low head socket cap screw clearance
- (1) M6 indexing pin
- ISO 9409-1 standard 40-4-M6

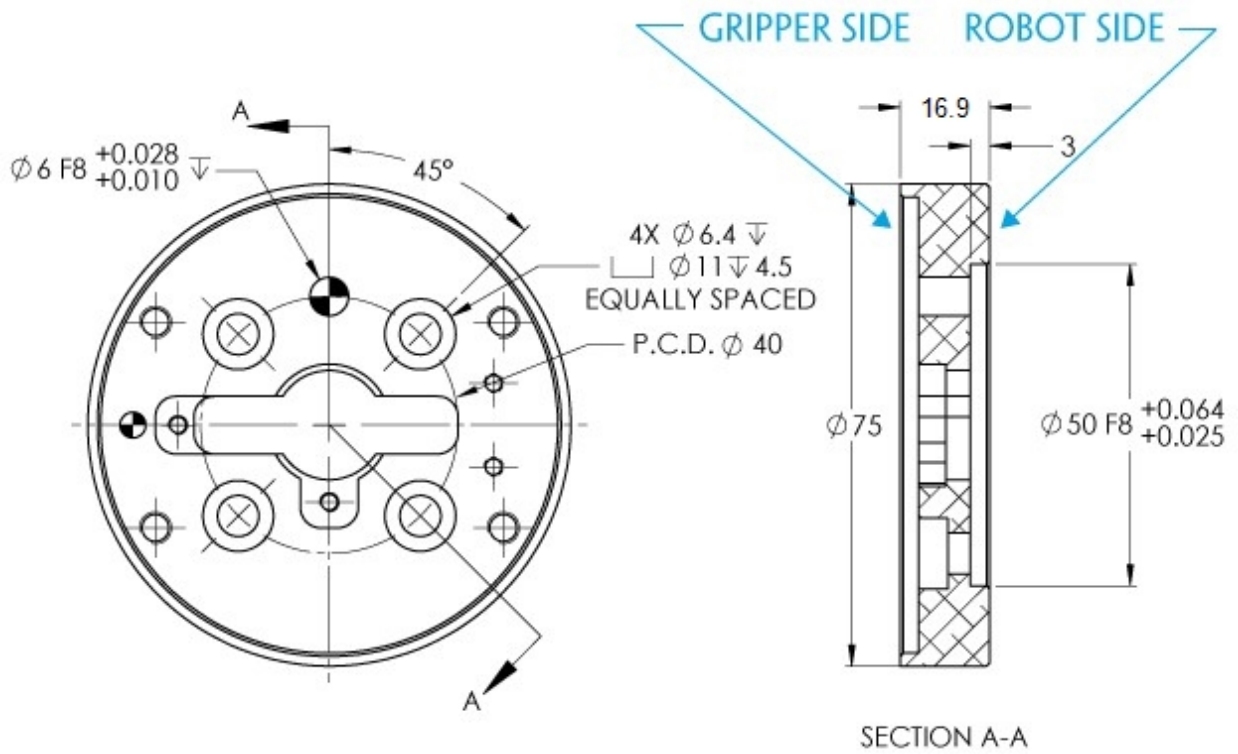

Fig. 6-10: Coupling for ISO 9409-1-40-4-M6.



Coupling for PCD 56 with 8 x M4

Bolt pattern for coupling AGC-CPL-065-002 (refer to the **Spare Parts, Kits and Accessories** section) is compatible with :

- 56 mm pitch circle diameter :
 - (8) M4-0.7 low head socket cap screw clearance
 - (1) M4 indexing pin
- 62 mm diameter internal insert

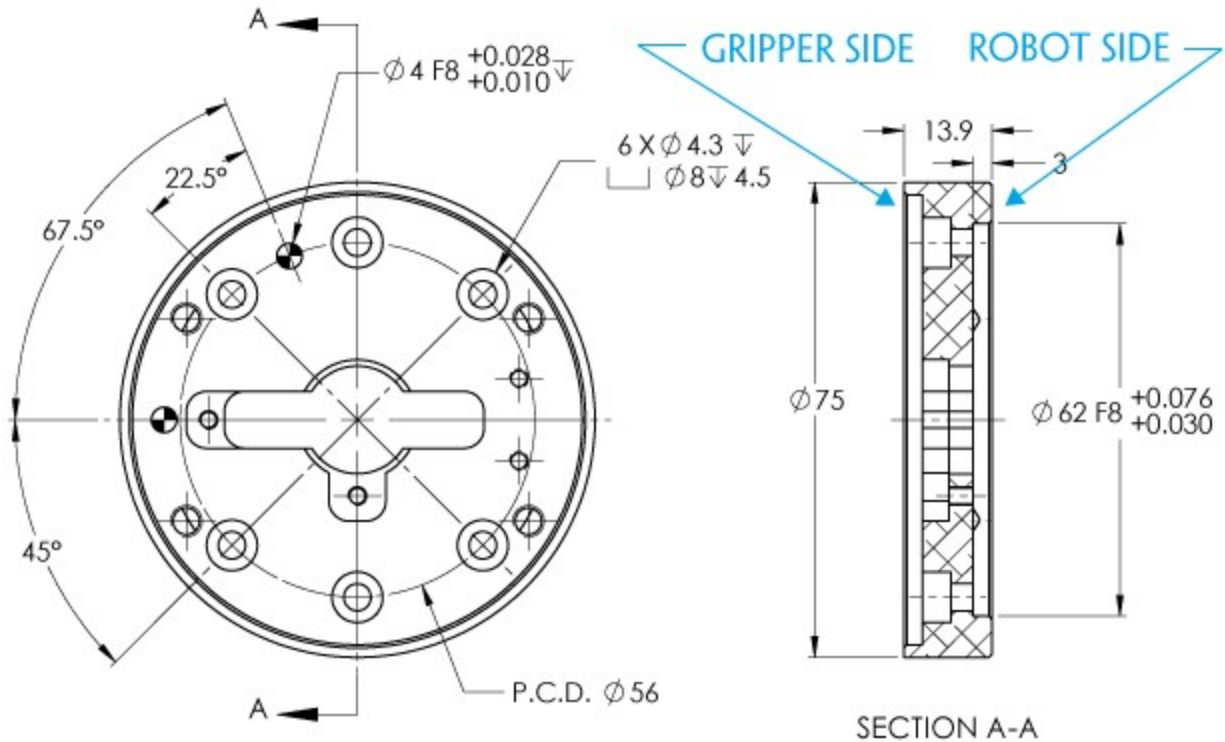

Fig. 6-11: Coupling for PCD 56 mm with 8 x M4 clearance.

Info

Although coupling AGC-CPL-065-002 is compatible with 8 x M4 threads on a 56 mm PCD it uses only 6 of the 8 normally present holes.



Coupling for PCD 56 with 6 x M4

Bolt pattern for coupling **AGC-CPL-066-002** (refer to the **Spare Parts, Kits and Accessories** section) is compatible with:

- 56 mm pitch circle diameter:
 - (6) M4-0.7 low head socket cap screw clearance
 - (1) M6 indexing pin
 - 42 mm diameter external insert

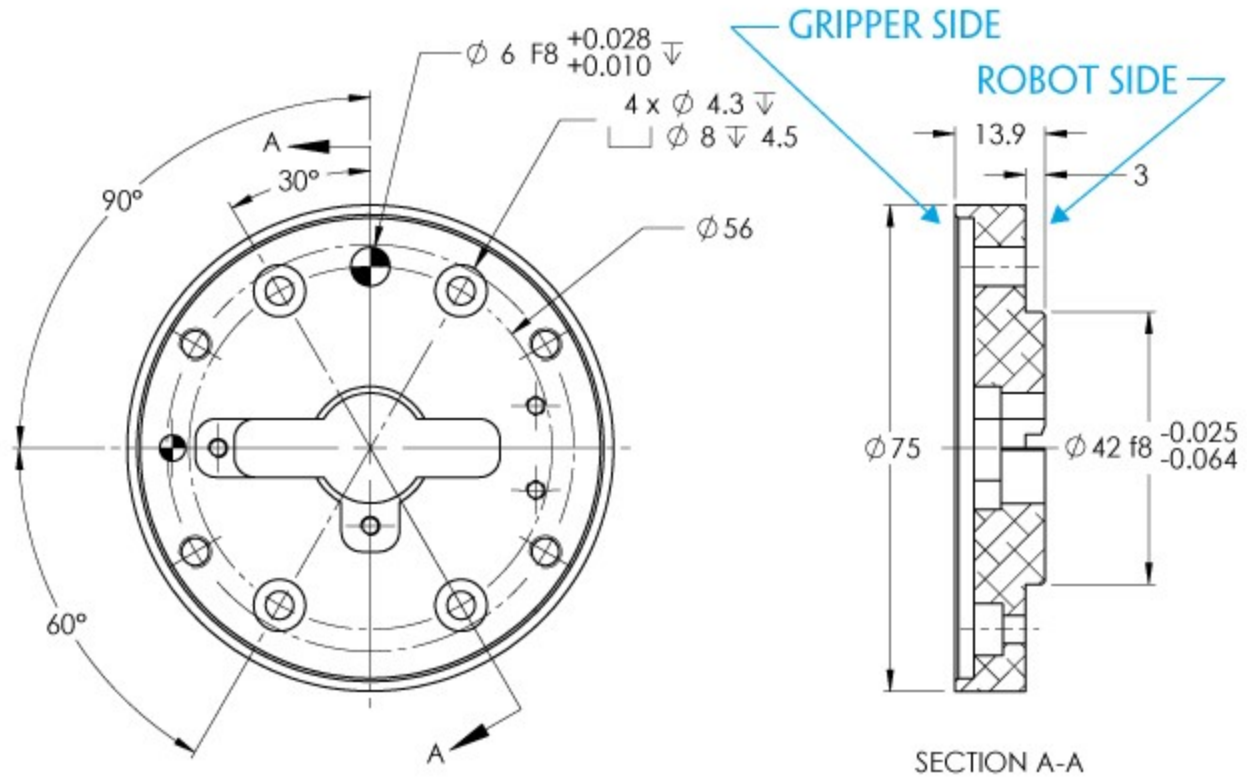

Fig. 6-12: Coupling for PCD 56 mm with 6 x M4 clearance.



Coupling for PCD 60 with 4 x M5

Bolt pattern for coupling **AGC-CPL-067-002** (refer to the **Spare Parts, Kits and Accessories** section) is compatible with :

- 60 mm pitch circle diameter :
 - (4) M5-0.8 low head socket cap screw clearance
 - (1) M5 indexing pin
 - 34 mm diameter external insert

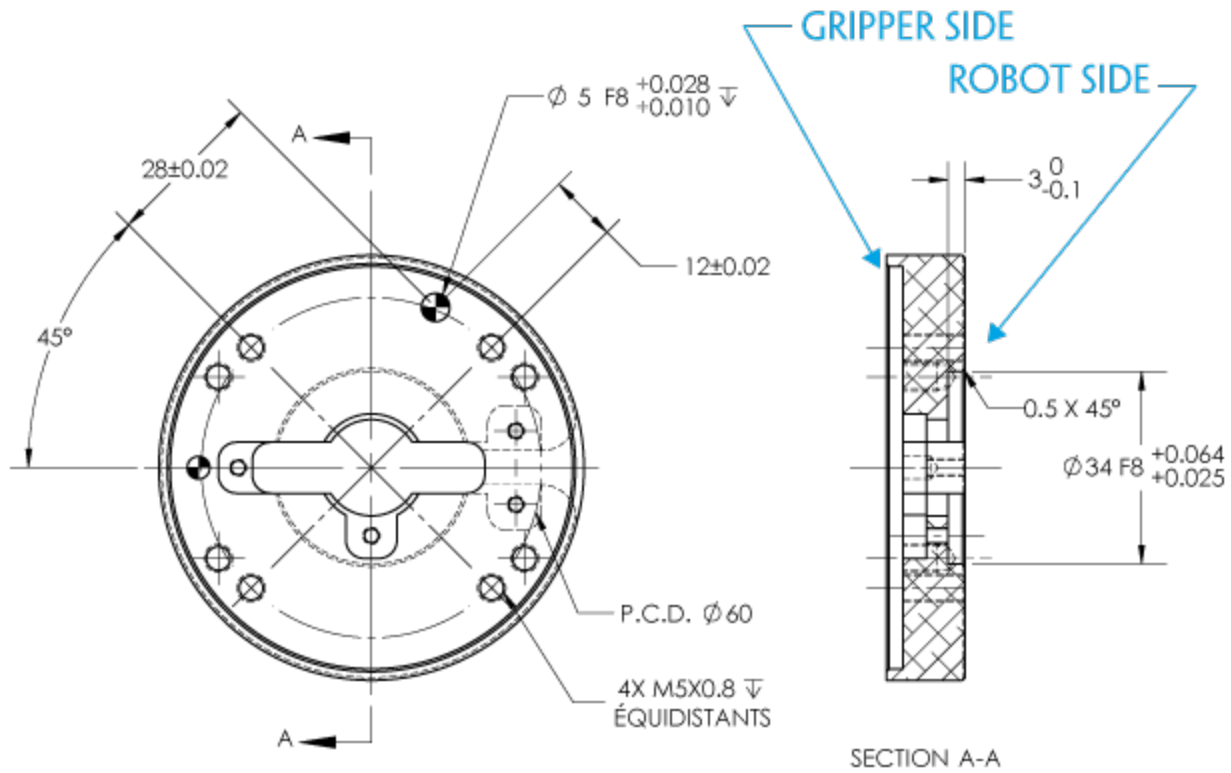

Fig. 6-13: Coupling for PCD 60 mm with 4 x M5 clearance.



Coupling for PCD 63 with 6 x M6

Bolt pattern for coupling AGC-CPL-068-002 (refer to the **Spare Parts, Kits and Accessories** section) is compatible with :

- 63 mm pitch circle diameter :
 - (6) M6-1.0 low head socket cap screw clearance
 - (2) M6 indexing pins

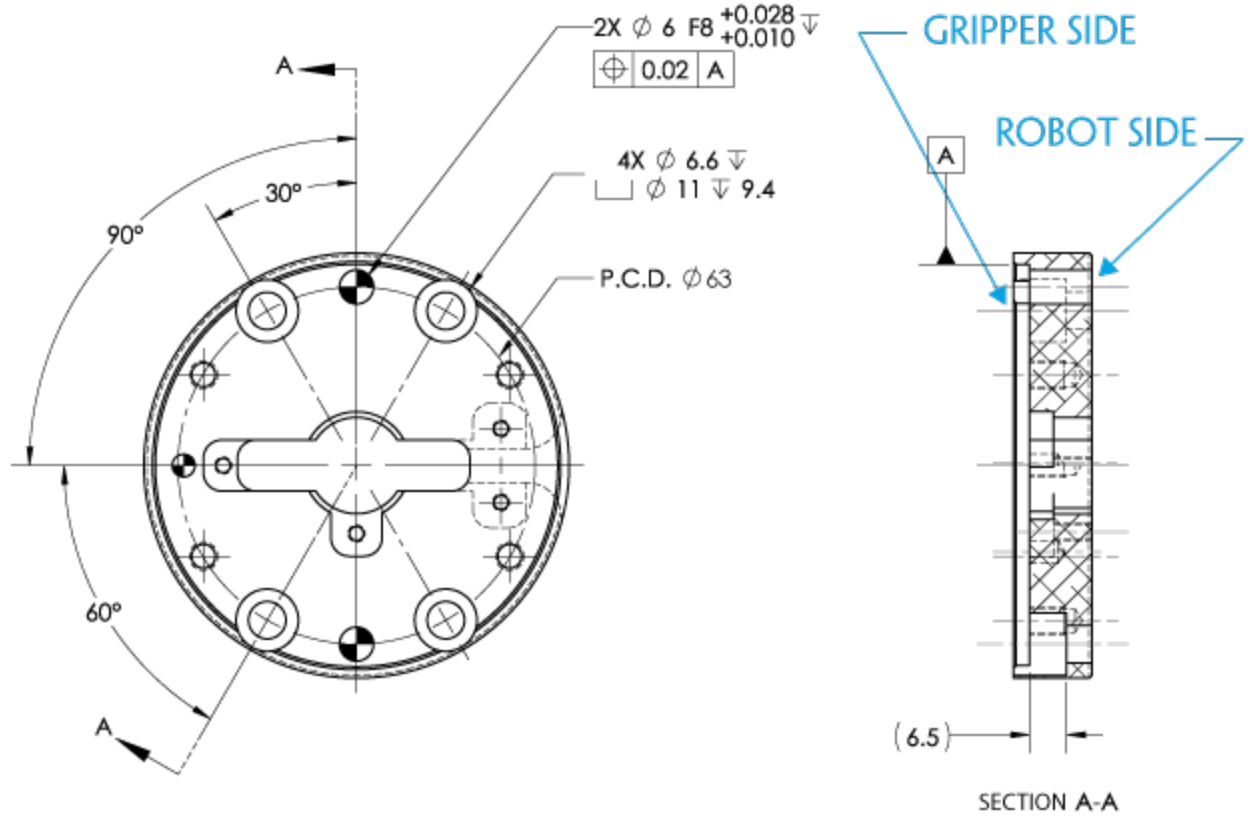

Fig. 6-14: Coupling for PCD 63 mm with 6 x M6 clearance.



6.2. Mechanical specifications

Specifications	EPick Vacuum Gripper	
	Metric Units	Imperial Units
Energy source	Electricity	
Gripper mass (including coupling)	710 g	1.55 lbs
Maximum vacuum level	80 %	
Maximum mean flow	12L/min	3.17 gal/min
Payload range ¹	0-10 kg	0-22 lbs
Gripping time ²	150 ms	
Release time ²	180 ms	
Noise level	64 dBa	
Maximum torque permissible by custom suction cup bracket	150 Nm	110 lbf-ft

¹ The payload range is for a non-porous surface with four suction cups of 55 mm diameter at 80% of vacuum level.

² The Gripping and Release time is the time for one suction cup of 40 mm and can vary according to the suction cups configuration and vacuum level.

Table 6-1: Specifications of the EPick Gripper

Info

All specifications are measured with coupling **GRP-CPL-062**.



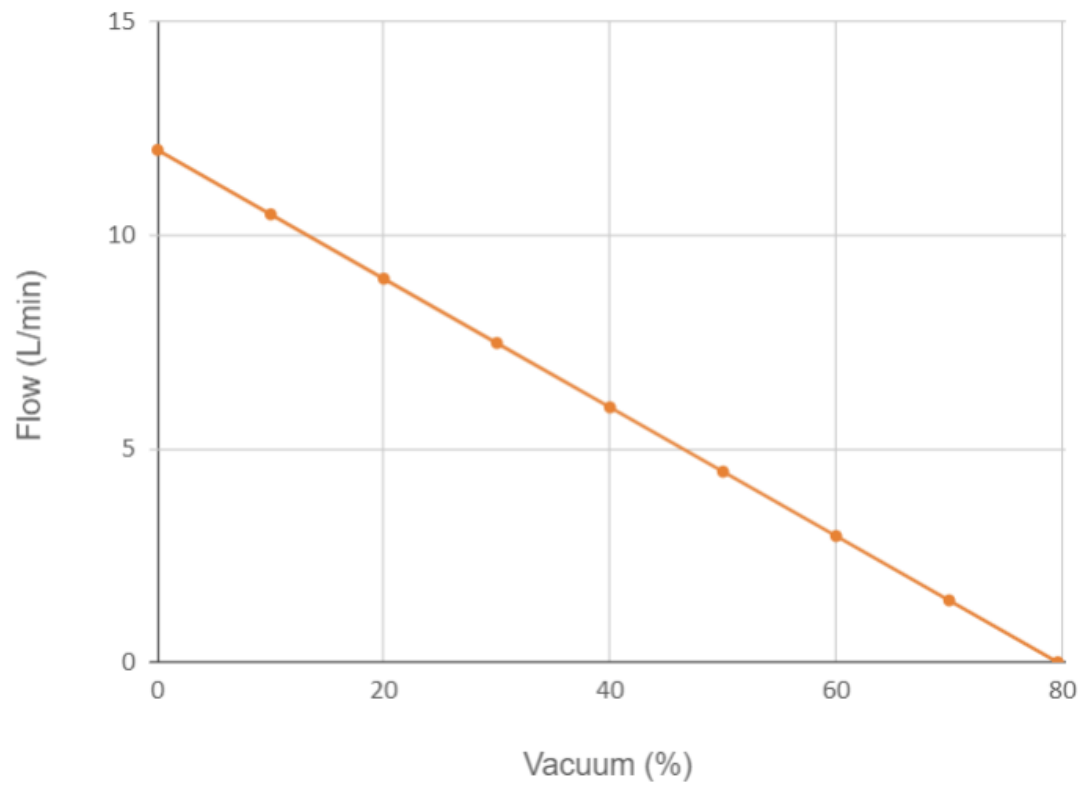

Chart 6-2: Flow (L/min) vs Vacuum (%)



6.2.1 Payload and force

When a load is to be picked by a Vacuum Gripper, several factors have to be considered. One of them is the vacuum level percentage selected. This value represents the pressure difference between the inside of the system and the ambient pressure. This table is valid for a nominal atmospheric pressure of 101,3 kPa.

Vacuum level (%)	Pressure difference (kPa)
0	0
10	10.1
20	20.3
30	30.4
40	40.5
50	50.7
60	60.8
70	70.9
80	81.1
90	91.2
100	101.3

Table 6-3: Conversion of absolute pressure to vacuum level



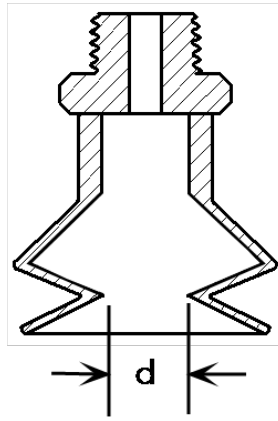

Fig. 6-15: Suction cup with inside diameter

Depending on the selected suction cup, the maximum grip strength can be determined with the following equation:

$$F_p(N) = \frac{A \times P \times n}{1000}$$

Where:

- A= Suction cups internal surface (mm²)
- P= Vacuum Level (kPa)
- n= Quantity of suction cups to lift-off

For more details, please refer to the specifications provided by the suction cup manufacturer.

The payload is the mass to be lifted according to an acceleration and an applied safety factor. There are three main types of load application that are represented in the following cases. Note that the arrows represent the robot movement.

Case #1

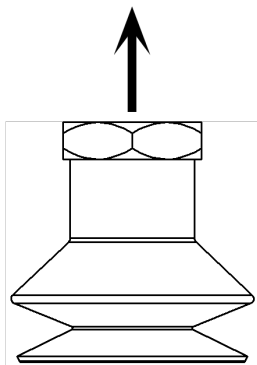

$$F_c = m \times (g + a) \times S$$

Case #2

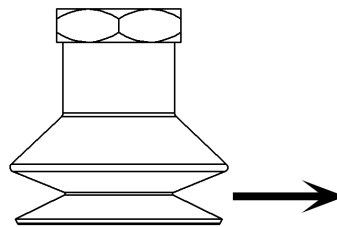

$$F_c = m \times \left(g + \frac{a}{\mu}\right) \times S$$

Case #3

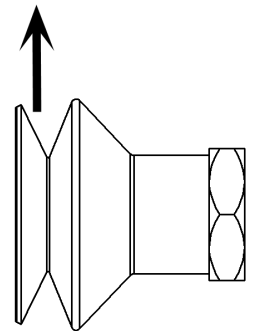

$$F_c = \frac{m}{\mu} \times (g + a) \times S$$

Where:



- M = mass (kg)
- G = gravitational acceleration (m/s^2)
- A = robot acceleration (m/s^2)
- μ = friction coefficient
- S = safety factor

The maximum grip strength of the suction cup must always be bigger than the payload ($F_p > F_c$) to guarantee the good grip of the piece. Robotiq recommends a minimum security factor of 2 in every case. However, a factor 4 is recommended for the next situations:

- Low friction coefficient
- Important robot acceleration
- Non-uniform surface
- Porous surface
- Unequal distribution of the payload in regards to the suction cups

Two categories of material can be lifted by the vacuum gripper: porous and non-porous. A non-porous material is defined as a material where air leakages are negligible and where it is possible to precisely attain a vacuum percentage between 10 and 80%.

Example 1: Non-porous material

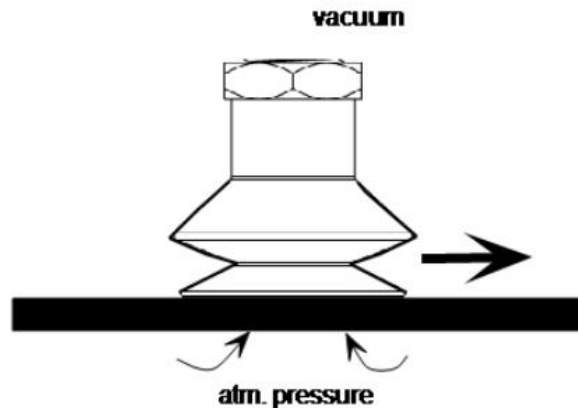

Fig. 6-16: Non-porous material

Initial data:

- Material type: non-porous
- Application type: Case #2
- Suction cup diameter (d): 40 mm ($r=20$ mm)
- Percentage of vacuum: 60% (which is equivalent to 60.8 kPa, according to the conversion table above)
- Mass: 2 kg
- Acceleration: 1.2 m/s^2
- $n = 4$

$$F_p(N) = \frac{A \times P \times n}{1000}$$

$$A = \pi \times r^2$$

$$A = 1256,6 \text{ mm}^2$$

$$F_p(N) = \frac{1256,6 \times 60,8 \times 4}{1000}$$

$$F_p(N) = 305,6 \text{ N}$$

Case #2

- $m = 2 \text{ kg}$
- $g = 9,81 \text{ m/s}^2$
- $a = 1,2 \text{ m/s}^2$
- $S = 4$ (recommended)
- $\mu = 0,5$

$$F_c = m \times \left(g + \frac{a}{\mu} \right) \times S$$

$$F_c = 2 \times \left(9,81 + \frac{1,2}{0,5} \right) \times 4$$

$$F_c = 97,7 \text{ N}$$

Validation that $F_p > F_c$: $305,6 \text{ N} > 97,7 \text{ N}$

Since $305,6 \text{ N} > 97,7 \text{ N}$, the rule is respected and we can ensure the good grip of the part.

Example 2: Porous material

For porous material, non-negligible air leakages can be observed. Therefore, the use of the EPick is not recommended. Considering that, the Vacuum Gripper will work in a continuous mode to compensate leakages and the reached vacuum will depend on 4 main factors:

1. Pump flow rate
2. The model of suction cups
3. Porosity of materials
4. Payload to lift



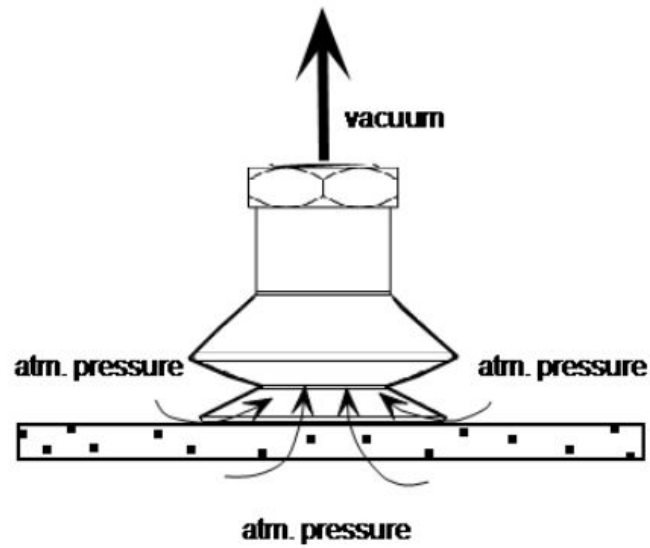
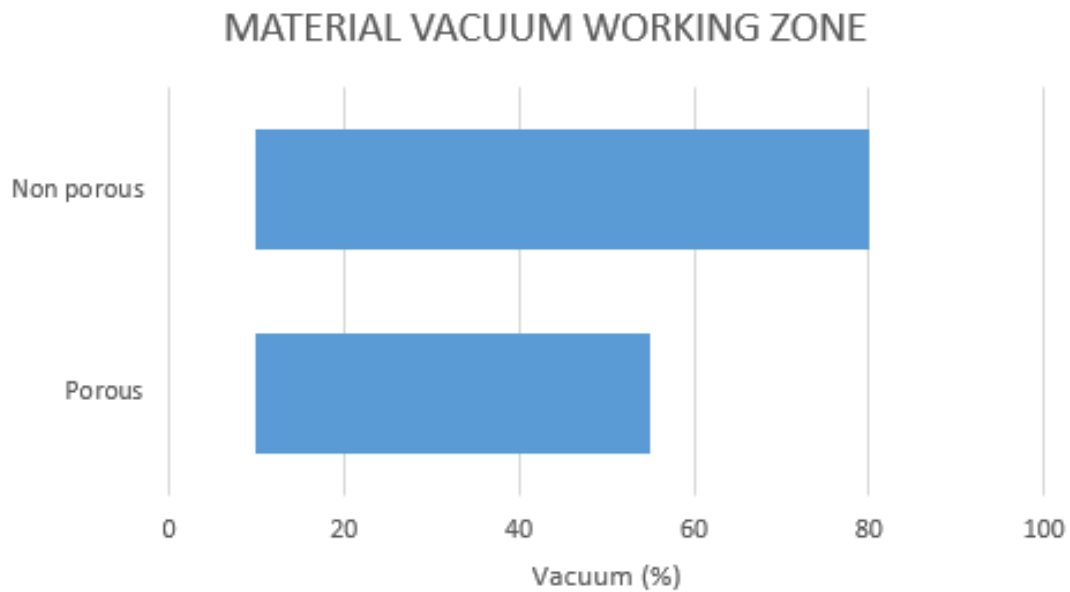

Fig. 6-17: Porous material



Info

Robotiq recommends to do some tests to determine the maximum grip strength of the suction cup, depending on the selected material to lift. It is not recommended to operate the robot with vacuum levels lower than 10%.



Info

Cardboard material should give percentage vacuum values lower than 15%.

Initial data:

- Material type: porous
- Application type: Case #1

Case #1

$$F_c = m \times (g + a) \times S$$

- $m = 0.2 \text{ Kg}$
- $g = 9.81 \text{ m/s}^2$
- $a = 1.2 \text{ m/s}^2$
- $S = 4$ (recommended)

$$F_c = 0,2 \times (9,81 + 1,2) \times 4$$

$$F_c = 8,8 \text{ N}$$

A test has been made with this material and it was statistically possible (without any acceleration) to pick a mass of 1 kg.

$$F_p = 1 \times 9,81 \text{ m/s}^2$$

$$F_p = 9,81 \text{ N}$$

Since, $F_p > F_c$ ($9.81 \text{ N} > 8.8 \text{ N}$), it is possible to lift a mass of 0.2 kg, as required.



6.2.2. Center of mass and tool center point

Couplings are included in the calculations when Vacuum Grippers are not mounted on the Robotiq Wrist Camera. Dual Gripper adapter plates are included where appropriate

Products	Center of mass (mm)			TCP (mm)			Mass (g)
	X	Y	Z	X	Y	Z	
FT Sensor	0.0	0.0	17.0	0.0	0.0	37.5	300.0
Camera	0.0	5.0	9.0	0.0	0.0	23.5	230.0
E-pick (without suction cups)	0.0	0.0	51.5	0.0	0.0	113.0	710.0
E-pick (with one suction cup)	0.0	0.0	55.2	0.0	0.0	145.0	745.0
E-pick (with 2 suction cups)	0.0	0.0	81.8	0.0	0.0	196.0	1120.0
E-pick (with 4 suction cups)	0.0	0.0	91.9	0.0	0.0	196.0	1345.0
FT Sensor + E-Pick	-1.0	0.0	65.7	0.0	0.0	150.5	1040.0
FT Sensor + E-Pick (with one suction cup)	-0.9	0.0	69.1	0.0	0.0	182.5	1075.0
FT Sensor + E-Pick (with 2 suction cups)	-0.7	0.0	95.7	0.0	0.0	233.5	1450.0
FT Sensor + E-Pick (with 4 suction cups)	-0.6	0.0	107.0	0.0	0.0	233.5	1675.0
Camera + E-Pick	-1.0	1.5	48.7	0.0	0.0	126.5	790.0
Camera + E-Pick (with one suction cup)	-0.9	1.4	52.2	0.0	0.0	147.5	825.0
Camera + E-Pick (with 2 suction cups)	-0.7	1.0	78.8	0.0	0.0	198.5	1200.0
Camera + E-Pick (with 4 suction cups)	-0.5	0.8	89.2	0.0	0.0	198.5	1425.0
FT Sensor + Camera + E-Pick	-1.6	1.0	65.4	0.0	0.0	153.0	1120.0
FT Sensor + Camera + E-Pick (with one suction cup)	-1.5	1.0	68.6	0.0	0.0	185.0	1155.0
FT Sensor + Camera + E-Pick (with 2 suction cups)	-1.2	0.8	94.6	0.0	0.0	236.0	1530.0
FT Sensor + Camera + E-Pick (with 4 suction cups)	-1.0	0.7	105.8	0.0	0.0	236.0	1755.0

Fig. 6-18: Center of mass and tool center point matrix.

The coordinate system used to calculate the moment of inertia and center of mass of the Vacuum Gripper is shown in the figure below.

$$I = \begin{bmatrix} I_{XX} & I_{XY} & I_{XZ} \\ I_{YX} & I_{YY} & I_{YZ} \\ I_{ZX} & I_{ZX} & I_{ZZ} \end{bmatrix} = \begin{bmatrix} 3084 & 0 & 0 \\ 0 & 2999 & 0 \\ 0 & 0 & 546 \end{bmatrix} = \begin{bmatrix} 10.5 & 0 & 0 \\ 0 & 10.2 & 0 \\ 0 & 0 & 1.6 \end{bmatrix}$$

kg * mm² lb * in²

Fig. 6-19: Inertia matrix for EPick Gripper.



6.2.3. Moment Limitation

The Vacuum Gripper has a maximum moment. The listed moment is independent to the force applied by the Gripper itself on it's payload. For payload calculation, refer to the **Mechanical specifications** section.

Warning

The following limits must be respected at all time. Calculation of maximum moment should include the robot acceleration and a safety factor.

Parameters	Maximum Value
Total moment	150 Nm

Table 6-4: Moment limitation of the Vacuum Gripper

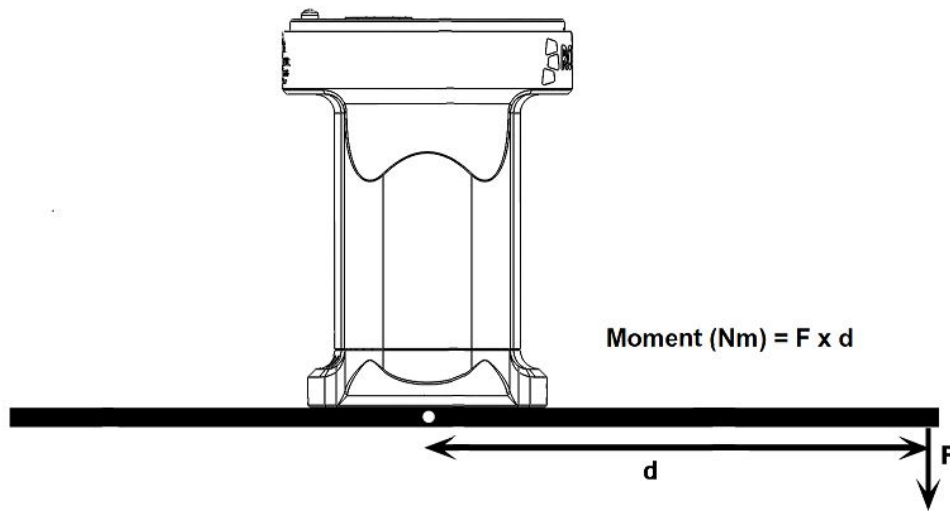

Fig. 6-20: EPick Moment limitation

6.3. Electrical specifications

SPECIFICATION	VALUE
Operating supply voltage	24 VDC \pm 10%
Quiescent power (minimum power consumption)	1 W
Peak current	1.8 A for 80 ms when vacuum pump starts

Table 6-5: Vacuum Gripper electrical specifications



7. Maintenance

The Vacuum Gripper only requires external maintenance with limited downtime. Maintenance is required after specified usage, measured in cycles (workpiece pick-up and release) or use time (hours).

Following the maintenance interval will ensure :

- Correct functioning of the Vacuum Gripper.
- Validity of the warranty.
- Proper lifetime of the Vacuum Gripper.

Warning

Unless specified, any **repairs** done on the Vacuum Gripper will be done by Robotiq.

Operation	Daily	Monthly	1 M cycles or 1,000 hours
Gripper Cleaning	Dirty conditions	Normal conditions	
Periodic Inspection			X

Table 7-1: Vacuum Gripper maintenance intervals

Caution

Maintenance operations are for the average normal usage of the Vacuum Gripper, the maintenance intervals must be adjusted according to the environmental conditions such as:

- Operating temperature
- Humidity
- Presence of chemical(s)
- Presence of physical objects (debris, scraps, dust, grease etc.)
- Interaction with operated parts (sharp or rough)
- Dynamics of the operation (accelerations)



7.1 Vacuum Gripper cleaning

Maintenance Interval	Tools You Need	Parts You Need
Monthly (or daily in dirty operating conditions)	<ul style="list-style-type: none"> • 4 mm hex key • Dry tissue or towel • Medium strength thread locker • Retaining ring plier 	Replacement filter (if required)

Table 7-2: Vacuum Gripper cleaning intervals.

Caution

The EPick Vacuum Gripper is not waterproof or water resistant without additional protection, only clean the Gripper with a dry towel.

Caution

Always turn off the robot, the Vacuum Gripper power supply before performing any maintenance operation on it.

Caution

Maintenance operator must be grounded to prevent electrostatic discharge that could damage the Vacuum Gripper electronics.

Caution

Do not use compressed air to clean the Vacuum Gripper. Doing so can result in a damage to the check valve or the release valve.

1. Remove the Vacuum Gripper from its coupling using the 4 mm hex key to unscrew the four (4) M5-0.8 x 25 mm socket head cap screws. Note that each screw uses a tooth lock washer, do not discard.
2. Clean the Vacuum Gripper with a dry towel, remove all debris, dirt and dust from its surface. Clean all suction cups. Dry thoroughly. Inspect the input filter to determine if it needs to be changed or not.
3. If the input filter needs to be changed, follow the steps:
 - i. Remove the retaining ring.
 - ii. Remove the old input filter.
 - iii. Install the new one and put back the retaining ring.



Tip

If the input filter needs to be changed, we recommend you to get a retaining ring plier for internal retaining rings of 0.038" tip diameter to help you replace it.

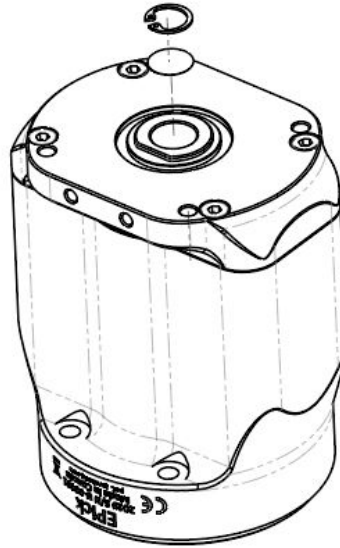

Fig. 7-1: EPick input filter change

4. Clean the coupling with a dry towel and pay a particular attention to the electrical contact.
5. Visually inspect the Vacuum Gripper and pay attention to any visible damage.
6. Put the coupling back on and secure using the four (4) M5-0.8 x 25 mm socket head cap screws. Use the tooth lock washers. Apply medium strength thread locker to the M5 screws.

When cleaning the Vacuum Gripper verify the wear of the suction cup. If wear is visible, change the suction cup. Please refer to the **Spare Parts, Kits and Accessories** section to order EPick replacement parts.

7.2. Periodic inspection

Maintenance Interval	Tools You Need	Parts You Need
Monthly	<ul style="list-style-type: none"> • Flat head precision 2 mm screwdriver • Dry tissue or towel • Medium strength thread locker 	None (unless damage is detected)

Table 7-3: EPick Gripper inspection intervals.

Info

Always turn off the robot and the Vacuum Gripper power supply before performing any maintenance operations.



1. Remove and clean the Vacuum Gripper following instructions in the **Vacuum Gripper cleaning** section.
2. Inspect the Vacuum Gripper :
 - a. Check for any collision damage. If damage is visible, contact support@robotiq.com.
 - b. Check for any sign of wear on the Vacuum Gripper chassis. If wear is present and may affect the Vacuum Gripper, contact support@robotiq.com.
3. Put the Vacuum Gripper back in place according to the instructions from the **Vacuum Gripper cleaning** section.

Suction cups and air nodes

Depending on your setup, mount the appropriate number of vacuum cups to their mating air bolts. If you need more information about the suction cups installation, please refer to **Suction cup system** section.

Warning

Any unused manifold port should be covered with a provided port plug to avoid air leakage.



8. Spare Parts, Kits and Accessories

Info

The following list is up to date at print time and is subject to change, check online for updates.

Info

Unless specified, screws, dowel pins and other hardware are included only for the Gripper side, never for the robot side.

Spare parts, kits and accessories list:

Item	Description	Ordering Number (1 Cup)	Ordering Number (2 Cups)	Ordering Number (4 Cups)
Kit for <i>Universal Robots</i> (e-Series)	EPick Kit for e-Series UR	VAC-ES-UR-EPICK-KIT1	VAC-ES-UR-EPICK-KIT2	VAC-ES-UR-EPICK-KIT4
Kit for <i>TM Robot</i>	EPick Kit for TM	VAC-TM-EPICK-KIT1	VAC-TM-EPICK-KIT2	VAC-TM-EPICK-KIT4
Kit for <i>TM Robot</i>	AirPick Kit for TM	VAC-TM-AIRPICK-KIT1	VAC-TM-AIRPICK-KIT2	VAC-TM-AIRPICK-KIT4
Kit for Omron-TM	EPick Kit for Omron-TM	VAC-OMRON-EPICK-KIT1	VAC-OMRON-EPICK-KIT2	VAC-OMRON-EPICK-KIT4
Kit for Omron-TM	AirPick Kit for Omron-TM	VAC-OMRON-AIRPICK-KIT1	VAC-OMRON-AIRPICK-KIT2	VAC-OMRON-AIRPICK-KIT4
Kit 2 Suction Cup System	Kit 4 Suction Cup System - 2 Suction Cups	VAC-SCS-KIT2		
Kit 4 Suction Cup System	Kit 4 Suction Cup System - 4 Suction Cups	VAC-SCS-KIT4		
Suction cup configuration - Screwing Kit	Suction cup configuration - Screwing Kit	VAC-SCS-SCREW-KIT		
Vacuum Suction Cup plate for 2 cups	Vacuum Suction Cup plate for 2 cups	VAC-SCS-PLATE-2		
Vacuum Suction Cup plate for 4 cups	Vacuum Suction Cup plate for 4 cups	VAC-SCS-PLATE-4		



Item	Description	Ordering Number (1 Cup)	Ordering Number (2 Cups)	Ordering Number (4 Cups)
Air node Plug and Play	Air node Plug and Play	VAC-SCS-NODE		
Vacuum Cup 1.5 Bellow 40 mm	Vacuum Cup 1.5 Bellow 40 mm	VAC-SCS-CUP40-2		
Vacuum Cup 1.5 Bellow 55mm	Vacuum Cup 1.5 Bellow 55 mm	VAC-SCS-CUP55-2		
Replacement filter	Filter for vacuum generator	VAC-SCS-FILTER		
ISO-9409-1-50-4-M6 coupling (coupling-to-wrist)	ISO 9409-1-50-4-M6 coupling for 2-Finger Robot Grippers, with screws for Gripper fixation	GRP-ES-CPL-062		
ISO 9409-1-31.5-4-M5 coupling	ISO 9409-1-31.5-4-M5 coupling for Adaptive Robot Gripper 2-Finger, with screws for Gripper fixation and 1 m pigtail cable	GRP-CPL-063		
ISO 9409-1-40-4-M6 coupling	ISO 9409-1-40-4-M6 coupling for Adaptive Robot Gripper Gripper 2-Finger, with screws for Gripper fixation and 1 m pigtail cable	GRP-CPL-064		
56-8M4-1D4 coupling	Coupling for 56 mm PCD ¹ with (8) M4 and (1) 4 mm indexing pin, with screws for 2-F Gripper fixation and 1 m pigtail cable	AGC-CPL-065-002		
56-6M4-1D6 coupling	Coupling for 56 mm PCD ¹ with (6) M4 and (1) 6 mm indexing pin, with screws for 2-F Gripper fixation and 1 m pigtail cable	AGC-CPL-066-002		
60-4Ø5-1D5 coupling	Coupling for 60 mm PCD ¹ with (4) M5 thread and (1) 5 mm indexing pin, with screws for 2-F Gripper fixation and 1 m pigtail cable	AGC-CPL-067-002		
63-6M6-2D6 coupling	Coupling for 63 mm PCD ¹ with (6) M6 and (2) 6mm indexing pins, with screws for 2-F Gripper fixation and 1 m pigtail cable	AGC-CPL-068-002		
40-4M5-1D3 coupling	Coupling for 40 mm PCD ¹ with (4) M5 and (1) 3mm indexing pins, with screws for 2-F Gripper fixation and 1 m pigtail cable	AGC-CPL-070-002		
31.5-4M4 coupling	Coupling for 31.5 mm PCD ¹ with (4) M4, with screws for 2-F Gripper fixation and 1 m pigtail cable	AGC-CPL-071-002		
Adapter plate to 63-4M6-71-2D3	Wrist adapter plate for use with AGC-CPL-064-002. Interface to 63 mm PCD ¹ with (4) M6 screws and 71 mm PCD ¹ with (2) M3 indexing pins	AGC-APL-151-002		
Adapter plate to 63-4M6-61_4-2D6	Wrist adapter plate for use with AGC-CPL-064-002. Interface to 63 mm PCD ¹ with (4) M6 screws and 61.4 mm PCD ¹ with (2) M6 indexing pins	AGC-APL-152-002		
Adapter plate to 80-6M8-2D82D8	Wrist adapter plate for use with AGC-CPL-064-002. Interface to 80 mm PCD ¹ with (6) M8 screws and (2)	AGC-APL-153-002		



Item	Description	Ordering Number (1 Cup)	Ordering Number (2 Cups)	Ordering Number (4 Cups)
	M8 indexing pins			



9. Troubleshooting

9.1 Communication

When using EPick Vacuum gripper with USB to RS485 serial converter:

Troubleshooting from the Gripper LED:

1. LED is not lit, Gripper not powered.
 - a. Check Gripper power supply and electrical setup
2. LED is solid blue and red, Gripper is in fault.
 - a. Disconnect the communication and power cycle the Gripper. The LED should turn solid red when powered.
 - b. While powered with red LED, connect the communication, LED should turn solid blue when connection is established.
3. Flashing blue and red LED, Gripper is in fault.
 - a. Gripper may be in auto-release, wait for auto-release to be completed, then turn off auto-release and initialize the Gripper.
 - b. Gripper may have a major fault, check the error from fault status and contact support.
4. Solid blue, no fault and communicating.
 - a. If you can control the Gripper from the GUI on the pendant, check your program structure.
 - b. If you can not control the Gripper from the pendant, contact support.
5. Solid red, no fault, but Gripper is not communicating.
 - a. USB-RS485 converter LEDs are :
 - Not lit, no USB communication.
 - i. Check USB connection.
 - ii. Re-install drivers.
 - iii. Contact support.
 - Red flashes at slow rate.
 - i. Check the DB-9 connector.
 - ii. Check the cable.
 - iii. Check the communication parameters from the Robotiq User Interface, see recovery procedure.
 - iv. Contact support.
 - Red and green flashing at high speed.
 - i. Check fault status, maximum operating temperature could be exceeded.
 - ii. Contact support.



When using EPick vacuum gripper with Universal Robots package:

Troubleshooting from the previous section (LED references) still applies.

From the UR teach pendant:

URCap install:

1. Verify that the latest URCap is installed by tapping the **triple bar icon** in the upper right corner, selecting **Settings**, then tapping the **System** menu and the **URCaps** button in the navigation pane on the left
 - a. URCaps installation instructions are in the **Installation** section
 - b. Inside the URCaps menu, if you select the appropriate URCap file, you can see the current software version
 - c. The Gripper toolbar should appear if installed properly
2. URCap is installed but Gripper cannot be controlled :
 1. If Gripper LED is not blue, follow the steps in the first section above
 2. If Gripper LED is blue, URCap is installed with the latest available version, contact support@robotiq.com



Driver package install:

1. Driver checkup :
 - a. Use the latest driver version available at support.robotiq.com
 - Use the installation instruction from the **Installation** section
 - b. To check your driver version :
 - With the Gripper unplugged
 - From the UR teach pendant screen, click the " Gripper" button
 - i. Driver version will be shown
 - ii. If Gripper button is not displayed, driver package is not properly installed, see instruction from the
2. Driver is installed but Gripper cannot be controlled :
 - a. If Gripper LED is not blue, follow the steps in the first section above
 - b. If Gripper LED is blue, driver is installed with the latest available version, contact support@robotiq.com

9.2. Vacuum Gripper verification

If you are not able to attain the desired vacuum level or if a diminution of the vacuum level occurs, verify:

- The suction cups status
- That the air path is clean and not obstructed (including the manifold)
- If a filter cleaning is necessary



10. Warranty

Robotiq warrants the EPick Gripper against defects in material and workmanship for a period of one year from the date of reception when utilized as intended. Robotiq also warrants that this equipment will meet applicable specifications under normal use.

Warning

Warranty applies under the following conditions:

- Usage respects the operating and storage conditions specified in **Environmental and Operating Conditions** section.
- Proper installation of the Vacuum Gripper specified in **Installation** section and the following subsections.
- Until one of these condition is reached:
 - 1 year
 - 2 000 000 cycle count¹
- Usage respects maintenance specified in the **Maintenance** section.
- Usage respects recommended payload and force specified in the **Mechanical specifications** section.

¹Cycle count: One (1) cycle is defined as a successful object gripping attempt. It is calculated in the internal memory of the EPick Gripper and can be seen on the robot teach pendant when using with the Universal Robots or with the Robotiq User Interface.

During the warranty period, Robotiq will repair or replace any defective EPick Gripper, as well as verify and adjust the Vacuum Gripper free of charge if the equipment should need to be repaired or if the original adjustment is erroneous. If the equipment is sent back for verification during the warranty period and found to meet all published specifications, Robotiq will charge standard verification fees.

The unit is considered defective when at least one of the following conditions occurs:

- The Vacuum Gripper feedback necessary for the robot program is not accessible.
- Wear of the Vacuum Gripper components due to direct contact with the workpiece or obstacles is not covered by the warranty.

Caution

The warranty will become null and void if the :

- Unit has been tampered with, repaired or worked on by unauthorized individuals.
- Screws, other than as explained in this guide, have been removed.
- Unit has been opened other than as explained in this guide.
- Unit serial number has been altered, erased, or removed.
- Unit has been misused, neglected, or damaged by accident.

This warranty is in lieu of all other warranties expressed, implied, or statutory, including, but not limited to, the implied warranties of merchantability and fitness for a particular purpose. In no event shall Robotiq be liable for special, incidental, or consequential damages.

Robotiq shall not be liable for damages resulting from the use of the EPick Gripper, nor shall Robotiq be responsible for any failure in the performance of other items to which the EPick Gripper is connected or the operation of any system of which the Vacuum Gripper may be a part.



Exclusions

This warranty excludes failure resulting from: improper use or installation, normal wear and tear, accident, abuse, neglect, fire, water, lightning or other acts of nature, causes external to the Vacuum Gripper or other factors beyond Robotiq's control.

Robotiq reserves the right to make changes in the design or construction of any of its products at any time without incurring any obligation to make any changes whatsoever on units already purchased.



11. Harmonized Standards, Declarations and Certificates

11.1. Original EC declaration of incorporation



EC Declaration of Incorporation (original)

In accordance with the EC Machinery Directive 2006/42/EC, Annex II, 1., Section B.

The manufacturer:

Robotiq Inc.
966 Chemin Olivier, Suite 500
Lévis, Québec, Canada, G7A 2N1

hereby declares, under sole responsibility, that the product:

EPick / EPick Vacuum Gripper
All S/N
(and accessories)

complies with the following essential requirements of the European Directive 2006/42/EC on machinery:

1.1.2, 1.1.3, 1.1.5, 1.3.2, 1.3.4, 1.5.1, 1.5.2, 1.5.4, 1.5.8, 1.5.10, 1.5.11, 1.7.2.

Name and address of the person authorised to compile the relevant technical documentation:

Nicolas Tremblay, CEP, see manufacturer address.

The product is considered as partly completed machinery and has been evaluated in accordance with the following harmonised standard:

ISO 12100:2010 Safety of machinery – General principles for design – Risk assessment and risk reduction

The product must not be put into service until the final machinery into which it is to be incorporated has been declared in conformity with the provisions of the Directive 2006/42/EC, including amendments.

The manufacturer declares that the product complies with the following European Directives and harmonised standards:

- **2014/30/EU** Directive on the harmonisation of the laws of the Member States relating to electromagnetic compatibility
 - *IEC 61000-6-2:2016 Electromagnetic compatibility (EMC) - Part 6-2: Generic standards – Immunity standard for industrial environments*
 - *IEC 61000-6-4:2018 Electromagnetic compatibility (EMC) - Part 6-4: Generic standards – Emission standard for industrial environments*
- **2011/65/EU and amendment 2015/863** Directive on the restriction of the use of certain hazardous substances in electrical and electronic equipment
 - *EN 50581:2012 Technical documentation for the assessment of electrical and electronic products with respect to the restriction of hazardous substances*
- **2012/19/EU** Directive on waste electrical and electronic equipment (WEEE)

The manufacturer also declares the use of these other technical standards, as far as applicable:

ISO 9409-1:2004 Manipulating industrial robots – Mechanical interfaces – Part 1: Plates

The relevant technical documentation is compiled in accordance with part B of Annex VII of Directive 2006/42/EC and will be presented electronically by the manufacturer to competent national authorities, if required with a substantiated reason.

Signed in Lévis on June 14th, 2019

Jean-Philippe Jobin, Eng., M.Sc.
Chief Technical Officer



11.2. Applied standards

This section describes all applied harmonized standards for the design and production of the EPick Vacuum Gripper. Conformity of the product is only met if all instructions of the current user manual are followed. Among others; proper installation, safety measures and normal usage must be respected. A risk assessment specific to the user's final application must also be carried out.

Caution

Conformity of the product is only met if all instructions of the following manual are followed. Among others; installation, safety measure and normal usage must be respected.

The following standards have been applied:

ISO 12100	2010	Safety of machinery — General principles for design — Risk assessment and risk reduction
ISO 9409-1	2004	Manipulating industrial robots – Mechanical interfaces – Part 1: Plates
ISO 4414	2010	Pneumatic fluid power – General rules and safety requirements for systems and their components
IEC 61000-6-2	2016	Generic standards – Immunity standard for industrial environments
IEC 61000-6-4	2018	Generic standards – Emission standard for industrial environments
EN 50581	2012	Technical documentation for the assessment of electrical and electronic products with respect to the restriction of hazardous substances



12. Contact

www.robotiq.com

Contact Us

Phone

1-888-ROBOTIQ (762-6847)
(01) 418-380-2788 Outside US and Canada

Fax

1-418-800-0046

Technical support and engineering

option 3

Sales

option 2

Head office

Robotiq:
966, chemin Olivier
Suite 500
St-Nicolas, Québec
G7A 2N1
Canada



Where automation Pros come to share their know-how and get answers.

dof.robotiq.com

